



# Homeowner Maintenance Manual

PO Box 33025 St. Petersburg, FL 33733  
[www.maverick-risk.com](http://www.maverick-risk.com)  
Copyright 2023. All Rights Reserved

# Welcome to your new home!

The manual explains in simple and easily understood language your normal maintenance responsibilities, which should always be conducted in a prudent, cautious, and safe manner.

If you feel that certain types of maintenance or repairs are beyond your capabilities, we suggest and urge you to call a professional, licensed contractor to perform the needed work.

We have attempted to cover all your home's maintenance areas with as much pertinent information and their primary needs as possible. Since our manual is widely distributed in many states, some information may not pertain or apply to your geographic location. It is impossible to address every scenario or method of maintenance. If we have omitted anything and you are unsure of how to proceed, we suggest that you refer to the manufacturer's written instructions, or contact a local professional contractor.

**IMPORTANT NOTE** REGARDING ANY AND ALL MANUFACTURED ITEMS (*eg. appliances, garage doors, windows and doors, toilets, sinks, tubs, faucets, etc.*)

The suggestions and recommendations found in this manual are not intended to replace or substitute any of the manufacturer's recommendations. If you should notice a conflict between our suggestions and those recommendations provided by the manufacturer, the manufacturer's directions and guidelines always supersede our suggestions.

There are four chapters designed to acquaint you with the maintenance requirements and warranty information about your new home.

## **1: Homeowner Maintenance Checklists**

Provide several lists of important preventative maintenance procedures required at periodic intervals. By adhering to these checklists, you can discover and correct minor maintenance problems before they become a major expense.

## **2: General Information & Safety Tips**

Contains valuable information concerning public utilities coming into your home as well as a few safety tips that you should observe when doing routine maintenance.

## **3: Homeowner Maintenance Information**

Gives you an explanation of the basic components of your home. This section will note the normal repairs that may be required and give you helpful hints on how to care for your home.

## **4: Glossary of Construction Terms**

Defines for the layman descriptions and terms used in the construction industry. A few minutes spent reviewing this section can result in you having a more comprehensive knowledge of how your home is constructed and can be of great benefit when dealing with construction tradespeople.

**NOTE:** THIS MAINTENANCE MANUAL ADDRESSES VARIOUS TYPES OF CONSTRUCTION THROUGHOUT THE COUNTRY. THEREFORE, SOME OF THE CONSTRUCTION MATERIALS DESCRIBED IN THIS MAINTENANCE MANUAL MAY NOT BE APPLICABLE TO YOUR HOME.

# Table of Contents

## **CHAPTER 1. | HOMEOWNER'S MAINTENANCE CHECKLISTS**

After Move-In Checklist .....	6
Every Month Checklist .....	6
Every Six Months Checklist .....	7
Annual Checklist .....	8
Seasonal Checklist .....	8
A Special Checklist for Condensation, Mold & Mildew .....	9

## **CHAPTER 2. | GENERAL INFORMATION & SAFETY TIPS**

Utility Lines, Cables & Pipes .....	13
-------------------------------------	----

## **CHAPTER 3. | HOMEOWNER'S MAINTENANCE INFORMATION**

Air Conditioning and Heating .....	17
Appliances .....	21
Attic .....	22
Bathroom Maintenance .....	22
Ceramic Tile .....	22
Grout Stain Removal Guide .....	22
Cabinets .....	23
Cable TV .....	23
Concrete .....	24
Condensation/Mildew .....	25
Countertops & Vanity Tops .....	26
Doors .....	27
Door Hardware/Locks/Hinges/Keys .....	28
Electrical System .....	29
Lighting Fixtures .....	30
Smoke Detectors .....	31
Security System & Intercom .....	32
Exterior Wall Finishes .....	32
Fireplaces .....	33
Flooring - Carpet, Tile, Hardwood & Vinyl .....	34
Framing & Carpentry .....	37
Garage Doors .....	37
Interior Walls & Ceilings .....	37
Landscaping, Lawn, Shrubs and Sprinklers .....	38
Mirrors & Shower Enclosures .....	40
Painting & Caulking .....	40
Plumbing System .....	43
Plumbing Fixtures .....	46
Roofing, Gutters, Downspouts .....	49
Screen Enclosures .....	49
Shelving .....	50
Shutters (Hurricane) .....	50
Stairs .....	50
Swimming Pool .....	51
Windows/Screens .....	51
Appliance and Systems Catalog .....	53

## **CHAPTER 4. | GLOSSARY OF CONSTRUCTION TERMS**

Home Buyers Glossary of Construction Terms .....	56
--	----



# 1 | Homeowner Maintenance Checklists

## After Move-In Checklist

### BATHROOMS AND MAIN FLOORS

- ❑ Apply grout sealer to ceramic tile grout if you wish to give the grout additional protection against discoloration from spills and stains.

### ELECTRIC

- ❑ Locate the main circuit breaker in the electric panel box and show family members how to turn it off in case of an emergency.

### FIRE EXTINGUISHER

- ❑ Purchase a general purpose fire extinguisher for each floor of the home plus one small kitchen extinguisher in case of grease fires. Demonstrate proper usage to family members in case of emergency.

### FIRST AID KIT

- ❑ Keep first aid materials and a book on first aid procedures in an accessible location.

### FLOORING

- ❑ Attach furniture protectors underneath furniture legs to protect floor finishes.

### LANDSCAPING

- ❑ Review and implement recommendations in the Landscaping and Grading Section of this manual.

### PLUMBING

- ❑ Locate the main water line shut-off valve and all individual plumbing fixture valves and show all family members how to close them in case of a plumbing emergency.

### GAS

- ❑ If your home has natural gas, locate the gas shut-off valve by the gas meter and show all family members how to close it in case of an emergency.

## Every Month Checklist

### AIR CONDITIONING AND HEATING

- ❑ Check air filters and clean or replace as necessary
- ❑ Vacuum air supply and air return registers to remove dust and lint.

### GARBAGE DISPOSAL

- ❑ Clean disposal blades by grinding up ice cubes. Freshen it with baking soda and by grinding up citrus fruit rinds.
- ❑ Test and reset Ground Fault Circuit Interrupters (GFCI) breakers.

### INTERIOR CAULKING

- ❑ Check for cracks or separations in caulking around sinks, bathtubs, toilets, faucets, counter tops, back splashes, ceramic tile walls, ceramic floors, windowsills and any other areas originally caulked by your builder. To repair these areas, use an appropriate caulking compound and follow the caulking instructions in the relevant sections of this manual.

### RANGE HOOD FAN

- ❑ Clean or replace dirty filter.

### SPRINKLER SYSTEM

- ❑ Adjust sprinkler heads for proper coverage.

# Every 6 Months Checklist

## **CABINETS**

- Clean and apply a light coat of wax to wood-finish cabinets.

## **CAULKING/PAINTING**

- Check all areas originally caulked by the builder, especially exterior windows and doors.
- Check exterior paint and stain surfaces (especially stained doors) and refinish as needed.

## **DOORS**

- Check screws on door lock set and hardware, and tighten as necessary.
- Lubricate bi-fold and by-pass doors as necessary.
- Clean sliding door track and apply silicone spray to tracks as necessary. Caution – only use a silicone lubricant; oil will cause the rollers to deteriorate. Take the necessary steps to protect adjacent flooring from the silicone, as it may cause discoloring. Oil moving parts of the garage doors.

## **ELECTRIC**

- Check electrical extension and appliance cords. Replace frayed or split cords.

## **EXTERIOR FINISHES**

- Check for cracks and voids in exterior caulking and recaulk as necessary. Follow the maintenance instructions contained in the painting section of this manual.

## **ROOFING**

- Visually inspect roof from the ground for broken or missing tiles or shingles and gaps in flashing.
- Check and clean gutters and downspouts, if installed.

## **AIR CONDITIONING SYSTEM**

- Have HVAC contractor perform six-month maintenance check up if you live in the high temperature, high humidity area.
- Ensure that air supply registers are not blocked by rugs, draperies or furniture.
- Make certain the concrete foundation that the A/C unit sits on is level.
- Remove excess leaves from vents.

## **PLUMBING**

- Check assessable water supply lines and valves to sinks, toilets, refrigerator and clothes washer. Tighten if loose or leaking.
- Clean out faucet aerators, spray nozzles and drains.
- Check pipes and drains for water leakage.

## **WINDOWS**

- Check sills for caulking cracks or separations and re-caulk, as necessary.
- Check weather stripping around windows and repair or replace, as necessary.
- Check windows for smooth opening and closing operation. Clean tracks and lubricate as necessary, using silicone spray.
- Inspect window screens and repair or replace, as necessary.

## **FIRE EXTINGUISHERS**

- Check fire extinguishers to ensure they are fully charged.

## **SMOKE DETECTORS**

- Test detectors and change batteries if needed.
- Clean and/or vacuum.

# Annual Checklist

## ATTIC

- Check attic vents to ensure that soffit vents are not blocked with insulation and move insulation back to its original location if there are voids on the attic floor.
- Check inside attic for signs of roof leaks. Be extremely careful not to damage or disturb electrical wiring or plumbing pipes that may be in the attic.

*CAUTION: Be extremely careful entering, exiting and walking in the attic. If you are unsure performing this task, you should contact a contractor.*

## CABINETS

- Check drawers and hinges for proper alignment. Tighten and adjust as needed.

## DOORS

- Check and repair or replace weather stripping on exterior doors as necessary.
- Tighten all bolts on garage door.
- Check the fit of exterior doors at their thresholds. Many designs are adjustable.

## WINDOWS

- Check all windows for gaps in caulking on the exterior of the house.

## AIR CONDITIONING SYSTEM

- Have HVAC contractor perform annual maintenance check-up.

## CLOTHES DRYER

- Check dryer hose for lint. A clogged hose may decrease the drying efficiency of the dryer.

## FIREPLACE

- Have chimney professionally cleaned as necessary.
- Inspect chimney for nests.

## PLUMBING

- Remove water heater residue following instructions in the Plumbing Fixtures Section of this manual.

## PRESSURE CLEANING

- Clean roof tiles and asphalt shingles (where applicable) of mildew and dirt as necessary.
- Clean pool deck and reseal as necessary.
- Clean pavers, driveways, patios, and walks as necessary.
- Clean exterior finishes such as siding, stucco, brickwork, stone of mildew and dirt as necessary.

## SEPTIC TANK

- Check and clean as necessary.

# Seasonal Checklist

- Follow all instructions for safe operation of any fireplace or wood-burning stove.
- Brush snow off gutters and away from downspouts, as applicable.
- Remove ice and snow from concrete surfaces and avoid using de-icing agents with damaging salts.
- Decorate safely for the holidays. Do not overload circuits or use worn extension cords.
- Winterize/service sprinkler system.
- On pleasant days, open windows to allow house to breathe.
- If your home has hurricane accordion shutters, tracks should be lubricated and shutters tested prior to the start of the hurricane season.

# Special Checklist for Condensation, Mold & Mildew

## Interior Mold in Residential Buildings

Mold and mildew in residential homes is not new. Mold grows on damp or wet surfaces. Left untreated, mold spores can become airborne. Spores are like seeds when they settle on vulnerable surfaces and they can consume organic material since they are part of our ecological system, helping to recycle organic material.

Based on this information, detecting moisture is the key to resolving the problem. Musty air in the home is a warning sign. Homeowners need to be aware that, under the right conditions, some condensation could appear on walls, windows or in the air conditioning vents. In such cases, one must clean and dry these areas and increase the ventilation in the home. Obtain a dehumidifier for any area with persistent dampness, such as a basement that isn't air conditioned.

Uncontrolled mold can be a health hazard. Proper maintenance of your home will go a long way toward eliminating or keeping moisture and humidity to a minimum. Consult your personal physician or a local government health authority for guidance if there is any concern for your health. Use of some or all the items below will help to eliminate major problems with mold.

Mold can be prevented in areas where water has been spilled if a leak occurs. In such cases, water could get behind a wall and mold growth could occur. Look for discolored areas (usually black) or mold on surfaces. Such areas also can be caused by problems such as leaky pipes under sinks, windows left open for rain to come in, water leakage through uncaulked windows, leaky roofs, etc.

- Have your air-conditioning system serviced by a recognized professional company at least annually. Ask for advice from an air-conditioning specialist if you are unsure about proper usage of your air conditioner.
- When outside weather is warm with low humidity, open windows to allow air circulation through the house.
- Increase circulation of heated air.
- Run the air conditioner during humid months of the year.
- Obtain a dehumidifier for any damp areas of the home, such as steamy bathrooms, basement, indoor pool area or attached greenhouse.
- Repair any water leaks quickly.

Take measures to keep water away from the foundation. There are many other ways to care for particular situations but the best of all is to use common sense. The objective is to keep your home dry and free from leaks or water intrusion and excessive condensation.





# 2

## General Information & Safety Tips

## General Information & Safety

### Tips

Every aspect of building your home, from laying the foundation to the final coat of paint, is an art form and was done by a qualified professional selected by your builder. Your home will retain its value and you can experience the pride of ownership for years to come.

This manual is not intended to be a “Do-It-Yourself” step-by-step guide, but it does provide useful information about the care and maintenance of your home. Please bear in mind that any repairs made by the homeowner or someone hired by the homeowner may void the manufacturer’s or builder’s warranty on the item being repaired.

While it is important to know what you are doing before you attempt any repair, it is equally important to know when to stop. If the project is more complex than you originally thought and exceeds your ability to make the repair, call in someone who knows what they are doing. It is better to admit a lack of knowledge than to compound the problem and create a major expense.

Your local home improvement center or hardware store can provide you with a variety of services beyond selling you merchandise. They usually have “Do-It-Yourself” books that provide detailed information about specific areas of the home. Many of them offer classes on a wide range of subjects from carpet and tile installation to selecting the proper tools for any given job. Frequently the person waiting on you can provide useful information that will help you in selecting the right materials for the project.

### Personal Safety

Accidents happen. They are called accidents because they were never intended to happen. They frequently occur because of the lack of precaution by the injured party. If hindsight was foresight, very few homeowners would be found in hospital emergency rooms.

A few dollars invested in eye protection, proper shoes and gloves may prevent a serious injury. When working around fiberglass insulation (such as attic crawl spaces) always wear long sleeves and gloves. You should take a shower as soon as possible after finishing the project.

Every home should have one or more ladders. In selecting a ladder make sure that it meets your needs for reach and weight requirements. When working on or around electrical fixtures, never use an aluminum ladder. A ladder made of fiberglass is recommended for most applications. Pay close attention to the warning labels affixed to the ladder. They are there for your protection.

It is important to understand the function of any tool that you are using, especially power tools. Read all accompanying instructions carefully before attempting to use the tool.

If your home has a home stand-by generator, read the manufacturer’s maintenance manual before attempting any periodic maintenance.

Keep a first aid kit on hand. Remember, the trauma of a trip to the emergency room may be avoided if you use a little common sense when working in or around your home.

### Utility Lines, Cables & Pipes

Your local utility companies provide a variety of services to your home. In most cases, even though their lines cross your property, you have no ownership or control over them until they pass through a metering device (electricity, water and gas). In the case of telephone lines and coaxial cable, they must pass through an exterior wall. Service or alterations to any utility line should be done only by a competent, licensed professional.

### Emergency Shut-offs

Your builder will show you where the main shut-off valves and switches are in your home. Every qualified person in your home should know where these switches and valves are located and how to turn them off in an emergency.

## Electricity

Electricity does not discriminate. It is an equal opportunity killer. Never attempt any electrical repair unless you absolutely know what you are doing. For any additional service needs or major repairs, you should call a licensed electrical contractor.

Even when attempting a minor repair, you must have the electricity turned off to the device you are working on. This must be done at the circuit breaker box. Turning off a wall or lamp switch will not always prevent a shock. Every receptacle, lamp and electrical device is controlled by a circuit breaker in the main circuit breaker box. Each circuit should be labeled, and you should know its function.

Never try to defeat the purpose of a circuit breaker. If it frequently "trips," this is generally a sign of a more severe problem, and a competent, licensed electrician should be called. The following steps may prevent a severe electrical shock:

**A. Open the circuit breaker box and locate the proper circuit breaker. Turn it off.**

**B. Close the panel door and tape a note across the front of the box informing others that you have turned off a circuit breaker and not to touch anything. If you can lock the panel, do so.**

**DO NOT ATTEMPT ANY ELECTRICAL REPAIR UNLESS YOU ARE LICENSED AND QUALIFIED.**

**NOTE:** Entrance of telephone and coaxial television cables may be at the point most convenient to the utility company

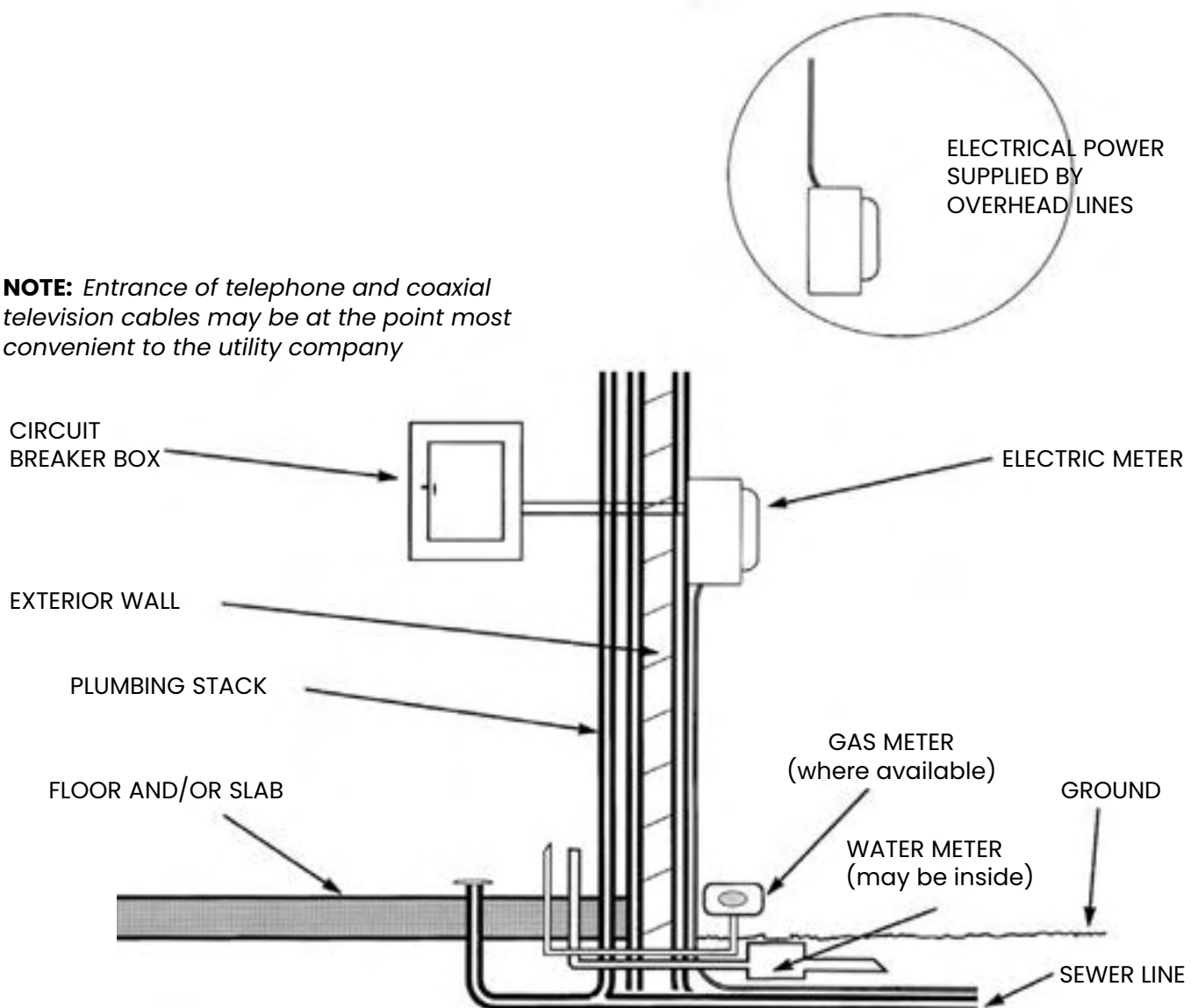



# 3

## Homeowner Maintenance Information

## Air Conditioning & Heating

### A. Air Conditioning & Heating Equipment

The air conditioning and heating equipment was installed by the HVAC (Heating, Ventilating and Air Conditioning) contractor.

The air conditioning and heating system(s) provides year-round climate control and consists of a thermostat to control temperature, an air handler unit to heat or cool the air, a filter to remove particles from the air, plus a fan unit to distribute and circulate air throughout the home via ducts and registers. Air conditioners have an outdoor condensing unit or compressor which must be kept sufficiently free of obstructions (such as shrubbery) to allow air to flow freely.

**NOTE:** *In certain areas of the country that experience extreme high temperatures, water-cooled air-conditioning systems may be used rather than air cooled systems. The difference between the two systems is how the heat is removed from the condenser. Water cooled units flow water over the condenser coils to remove heat and air-cooled systems blow air across the condenser to remove heat. In areas where there can be hard freezes, water must be drained from both the condenser unit and water supply line.*

**NOTE:** *Window coverings should be installed to maintain consistent room temperature. Direct sunlight entering the house will increase the temperature in the affected area and will also fade furniture and carpets.*

### **Maintenance Guidelines: Air Conditioning & Heating**

**Service Contract:** When there is a heavy demand on your HVAC system, take advantage of the extended annual service contract that is available from your air conditioner supplier. This contract typically provides seasonal check-ups of the heating and cooling components, plus periodic cleaning; the advantage being that scheduled service may reduce system failure by preventing problems before they occur.

### **Before Calling for Service**

1. Check to see that the thermostat is properly set.
2. Check the circuit breaker in the panel box. If tripped, reset by switching the breaker from the full "Off" position to "On." If the circuit breaker will not reset, contact the HVAC contractor.

3. Check the electrical disconnect switch, located on or near the air handler and reset.

4. Check the exterior disconnect switch located outside the home near the compressor and reset.

### **B. Air Filter**

The air filter, located adjacent to the air handler unit or in the return air grille, helps reduce the flow of dust into the air. As the filter collects dust, it reduces the system's efficiency and must be cleaned or replaced. Your builder has installed one air filter in each filter location and will, at the walk-through, demonstrate proper filter installation, cleaning and replacement procedures. After that, the homeowner is responsible for regular cleaning, replacement, and maintenance of air filters.

### **Maintenance Guidelines: Air Filter**

Monthly filter cleaning or replacement will provide cleaner air, improve air flow, and help reduce utilities costs. To remove, clean or replace filters, turn the air conditioner/ furnace and fan off using the thermostat control, then carefully remove the old filter and clean, or insert a new one. Replacement filters are available through hardware and home supply stores. Make sure to buy the correct size for replacement.

**NOTE:** *There are filters available that need to be replaced only every three (3) months and other filters that are washable and do not need to be replaced.*

### **C. Thermostat**

The thermostat controls the entire heating and cooling system. The thermostat provides a fan switch to circulate the air when neither heating nor cooling is needed.

To maximize energy efficiency and minimize utility bills, set the thermostat to a comfortable level normally between 68° F to 71° F for heating, and between 76° F to 78° F for cooling, and leave it there. Then set the fan switch to either the "ON" or "AUTO" position.

The less frequently you change the thermostat setting, the more comfortable you will be, the lower your utility bills will be, and less wear and tear on the system's compressor will incur. Changing settings frequently will cause the supplemental heater to run more often and turning the system on or off expends extra energy to bring the temperature back to a comfortable level. Setting air conditioning controls too low does not cool the home faster and the same principle applies to heating.

Programmable thermostats can save energy and money without sacrificing comfort and convenience by reducing the amount of time heating and cooling systems operate. You can program different temperature settings for different times of the day and days of the week based on when you are in your home. When programmed properly, the heating and cooling systems will operate less frequently, consume less energy and lower utility costs. Programmable thermostats can be purchased at hardware and home supply stores.

## D. Air Distribution System

**Duct Work:** Ducts carry and distribute heated or cooled air to each room.

**Registers:** Two kinds of registers are used: air supply registers (located on the wall or ceiling) that deliver warm or cooled air into the room; and air return registers (located on walls, ceilings or under the air handler access door) that return air from the room back into the air handler fan to be re-heated or re-cooled.

To regulate temperatures on different floors or rooms during different seasons, adjust the air supply registers by partially opening or closing them, thus restricting or moving additional air into each room.

Vacuum supply and return registers to ensure they remain dust free. Check that registers are not blocked by draperies, furniture or other obstructions that restrict normal air flow.

Interior doors in each room are undercut to allow return air to circulate throughout each room when the doors are closed. Do not close doors to regulate room temperatures.

**CAUTION:** *Burning candles for prolonged periods of time may, in some instances, create a phenomenon known as "ghosting." Ghosting occurs when soot from a burning candle is released into the air, carried throughout the house through the air conditioner, and expelled through the vents. The soot adheres to all surfaces including ceilings, fabrics and counter tops. It is especially visible on the car- pet at the base of bedroom doors. Cleaning is very difficult and is a homeowner's responsibility*

### How to avoid ghosting in your home:

1. Buy candles made with hard wax and with thin braided wicks that curl over when burned.

2. Buy candles with low aromatic properties and with wicks that burn with a low flame.

3. Buy candles with cotton or paper wicks and refrain from buying candles with metal-core wicks.

4. Do not allow candles to smoke and keep them out of drafts.

5. Keep matches and wick debris out of the candle.

6. Extinguish candles after one hour of continuous burning. Allow the candle to cool before relighting.

7. Large numbers of candles should be burned in the fireplace with the damper open to allow the smoke and emission to escape.

8. Stop using candles that leave a visible soot ring on their containers.

## E. Exterior Compressor/Condensing Unit

Keep the condensing unit (*compressor*) level and keep the area surrounding the unit clear to allow unimpaired air flow. Do not plant bushes too close to the unit and be careful that dirt, leaves and grass clippings are cleared away. For a thorough cleaning, contact an HVAC contractor. Do not build a deck around or over the compressor unless there is an 18-inch clearance on the sides and a 6-foot minimum clearance on top.

## F. Condensate Control

Dehumidification is part of the function of your air conditioning system. The moisture removed from the air is condensed into water and is then referred to as "condensate." The condensate forms and is collected on the evaporator coil which is located in the air handling unit (*except on one-piece package units*). The condensate drain removes the water. Regular maintenance should be performed by the A/C contractor of the drain pan and line to control algae build-up and eliminate water leaks.

### **Maintenance Guidelines: Condensate Control**

Install algae tablets in the condensate drain pan regularly. Flush condensate drain pan and lines regularly. Drains should be flushed from the inside of the house toward the outside. Never open the air handling unit without first disconnecting the power. Algae tablets are available through your air conditioning contractor or home improvement center.

## Helpful Hints

1. Check and replace or clean filters every month. Clogged filters mean higher operating costs.
2. Don't try to maintain different temperatures in different rooms by totally closing duct outlets – you will unbalance the system and reduce its efficiency.
3. Use bath and kitchen exhaust fans sparingly when air conditioning is operating.
4. To reduce the time your air conditioner must be on, do heat-producing chores such as baking and dish washing, during the cooler hours in the morning or evening.
5. Check weather stripping and caulking around doors and windows for leaks.
6. Shade your home with trees wherever possible.
7. Keep all windows and exterior doors shut when air conditioner is on.
8. Do not short-cycle your compressor by moving the thermostat up and down too rapidly.
9. Set your temperature slowly and leave it for at least five minutes before resetting.
10. In case of outside temperatures exceeding 95° F, a differential of 15° F is acceptable.

## G. Heat Pump

Your home may be equipped with an electric, forced-air heating system that includes a heat pump. The heat pump is an electrically powered, single refrigeration unit that provides both heating and cooling functions. It operates on the principle that outdoor air, even in winter, contains heat or thermal energy. During winter, the heat pump draws in outside air, extracts the heat and then circulates it throughout the home. In the summer the process is reversed, whereby the heat pump removes heat from indoor air, discharges it outdoors and then circulates cool air throughout the home.

A heat pump can be expected to operate continuously if outside temperatures fall below 50°F. Heated air coming from the registers feels cool to the touch

This is normal since the heat pump generates a low level of heat, sometimes below 90°F, while normal body temperature is 98.6°F.

**Supplemental Heat:** When outdoor temperatures fall to at least 50°F, the heat pump may be unable to draw sufficient heat from the outside air and a supplemental heating unit automatically turns on. You will know it is operating when the blue/green light on the thermostat is lit. The heating elements, located in the furnace unit's air handler, will turn on for a short time. The supplemental heat will also turn on if the thermostat is adjusted more than two degrees above room temperature.

**Emergency Heating:** Should the heat pump fail, activate the emergency switch on the thermostat. The red light indicates that it is on. This will stop the heat pump from operating and will provide supplemental heat until the HVAC contractor arrives.

**Defrosting:** During winter, ice can accumulate on the sides of the heat pump's exterior coil. When ice covers 80 percent of the surface, the system automatically activates a defrost cycle that lasts about five minutes, heating the coil to melt the ice. It will also activate the supplemental heat to prevent ducts from blowing cold air into the home during the defrost cycle. This process may occur several times each day, and you will notice that steam rises from the unit when it occurs. This is completely normal and is not cause for concern.

## Maintenance Guidelines: Heat Pump

Keep the heat pump unit level and keep the area surrounding the unit clear to allow unimpaired air flow. Do not plant bushes near the unit and be careful that dirt, leaves and grass clippings are cleared away. For a thorough cleaning, contact an HVAC contractor.

Do not build around or over the air conditioner unless there is an 18-inch clearance on the sides and a 6-foot minimum clearance on top.

## Solutions to Common Heating and Air Conditioning

PROBLEM	LIKELY CAUSE	SOLUTION
Air temperature in different rooms or floors is uneven	Air distribution unbalanced. Registers are obstructed.	Adjust air registers. Clear obstructions away from registers.
Reduced air flow or excessive dust on vents and registers.	Dirty air filter.	Clean or replace air filter as necessary.
Indicator light on thermostat stays on continuously.	Disconnect breaker at panel box tripped.	Check disconnect breaker. Reset or replace as necessary.
Heat pump, fan or air conditioner not operating.	Low refrigerant or dirty air filter.	Reset circuit breaker at panel box or unit.
Air conditioner or heat pump not operating properly.	Outside unit obstructed by debris: bushes leaves, etc.	Clear obstructions from top and sides of unit.
Inside air handler is leaking water.	Condensation drain clogged or inside coil is frozen.	Call HVAC contractor. Check manufacturer's warranty.
Inside or outside coil is frozen.	Low refrigerant or dirty air filter.	Call HVAC contractor. Clean or replace filter. Raise thermostat to 90° to thaw.
Excess water on window panes.	Excess humidity in home.	Adjust thermostat setting. Use exhaust fans while cooking or bathing.
Burning smell when winter or auxiliary heat first turned on.	Accumulated dust on electrical coils.	Normal. Happens once each year.
Blue/green light on the thermostat stays on continuously.	Disconnect Breaker tripped at heat pump.	Check disconnect breaker. Reset or replace as necessary.

## Appliances

Your home may be equipped with a variety of appliances, such as an electric oven, range hood, dishwasher, refrigerator, microwave oven, garbage disposal, washing machine and dryer. At move-in time, you should test all appliances for proper operation. Where applicable, fill out and mail in warranty card. Failure to do so may void the manufacturer's warranty. Review the manufacturer's service manuals for operation and maintenance instructions. File your manuals in a convenient location for future reference.

Many manufacturers offer toll-free customer service to answer questions about appliance problems and operation. Some helpful numbers are:

- **GE Service** 800-432-2737
- **Whirlpool** 800-253-1301
- **Kitchen Aid** 800-422-1230
- **JennAir** 800-688-1100
- **Sears** (Kenmore) 800-366-7278
- **Sub-Zero** 800-222-7820
- **Frigidaire** 800-374-4432
- **Amana** 800-628-5782
- **Maytag** 800-807-6777
- **LG Service** 800-243-0000
- **In-sink-Erator** 800-558-5700

For appliance repair protection that extends beyond the manufacturer's warranty period, we suggest you consider a service contract available through an appropriate local contractor or the manufacturer.

If you purchase your own appliances, carefully measure existing appliance openings to ensure proper fit. Check that doorway widths leading to the appliance location are wide enough to move the appliance through.

### Before calling for Service

If an electrical appliance fails to work, complete the following checklist before calling the appropriate contractor; otherwise, you may be charged for a service call.

1. Check that the appliance is plugged in.
2. If the appliance is plugged into a wall-switched electrical outlet, make sure the switch is "ON." If the appliance is plugged into a GFCI circuit, check and reset the button if necessary.
3. The circuit breaker on the panel box controlling the appliance should be in the "ON" position.

4. Some appliances come with their own separate fuses or circuit breakers. Review the manufacturer's service manual for the exact location, then check for proper setting.

5. Annually check the dryer vent for obstructions. Accumulated lint should be removed by disconnecting and then vacuuming the dryer vent.

## Helpful Hints

**Refrigerators/Freezer:** Check and clean the gaskets regularly to ensure a tight seal. Refrigerator and freezer temperatures should be set at the temperatures recommended by the manufacturer. DO NOT PLUG a refrigerator or freezer into a "ground/fault" (GFCI) receptacle, because the circuit may trip and not be discovered for some time, allowing the contents of the refrigerator or freezer to spoil.

**Dishwasher:** Use only when you have a full load. Use the shortest wash cycle.

**Cook Tops/Stoves/Ovens:** Do not allow dirt to accumulate. Clean with a recommended over-the-counter cleaner. Do not use harsh abrasive unless specified. Clean all filters regularly.

**Garbage Disposal:** Always use cold water when disposal is working. Corn cobs and husks, bones, celery or any other food that shreds should not be put into the disposal. If the machine becomes jammed, use the wrench to free the mechanism and try again. The disposal will rust if not used regularly. If you are going to be away for an extended period of time, a teaspoon of oil will help prevent the mechanism from freezing.

**Range Hood Fan or Microwaves:** The range hood fan filters collect grease and should be cleaned regularly. Soaking the filters or lightly brushing them in hot soapy water is the best cleaning method. Be sure the filters are dry before reinstalling them.

**Microwave Oven:** Be sure that vent louvers are not blocked.

## Attic

The attic space below the roof is part of the roof truss system. When inspecting the attic, walk on the wood members only. The drywall ceiling of the room below is not designed to support any weight.

### **Maintenance Guidelines: Attic**

The attic truss system is not engineered to support additional weight and should not be used for any storage purpose. Materials stored can also be a fire hazard.

Do not cover any vents with insulation or any other material. Insulation on the attic floor is for the thermal protection of the rooms below. If the insulation is moved, it will leave gaps between the insulation panels and may obstruct the attic vents. Always replace moved insulation back to its original position.

Building codes require attic and crawl space vents to minimize accumulation of moisture. Attic ventilation occurs through vents in the soffit (the underside of the overhangs) or on gable ends. Driving rain or snow sometimes enters the attic through these vents. Do not cover them to prevent this. Instead, cover the insulation in front of the vent. When you do this, precipitation that blows in safely evaporates and ventilation can still occur.

## Bathroom Maintenance

*Also see Ceramic Tile Walls and Plumbing sections*

**Mildew:** Moisture and mildew problems will occur in any room where water vapor is present. To reduce mildew, turn on the exhaust fan or slightly open a window when bathing. Wipe off wet tiles when done, then hang up towels and washcloths to dry. To clean mildewed surfaces and reduce mildew odors, apply a liquid mildew agent in a well-ventilated room, followed by a disinfectant and thorough rinsing with clear water. Moisture and mildew removal is a homeowner's responsibility.

**Soap Scum:** In some geographic areas, water that is high in mineral content can contribute to soap scum build-up. To clean and remove residue, wash the affected surfaces with a mild vinegar and water solution or use mildew removers found in most stores.

**Rust stains:** The contact of wet metal on sink surface, for example, the bottom of a shaving cream can, may

produce rust stains. To remove them, apply a powered rust remover, carefully following the manufacturer's instructions.

## Ceramic Tile

The ceramic tile walls in your bathrooms or kitchen are easy to maintain and, if property maintained, will be impervious to water. The seams, joints and sealers are not waterproof and require proper maintenance to prevent water seepage and damage to materials adjacent to and underneath the tile.

Cracks in the caulking joints between tile and tub, in the shower stall corners and at the floor, are normal and are caused by the degree of moisture present in every bathroom, as well as from the normal shrinkage of caulking material. Separation between the tub and wall tile is caused by the weight of the tub filled with water.

Regrouting and recaulking are homeowner's responsibilities for the life of the home. For other problems concerning bathtubs, sinks, etc.

## Grout Stain Removal Guide

STAIN	REMOVAL AGENT
Grease and fats	Soda and water or commercial spot lifter
Inks and dyes	Household bleach
Mercurochrome	Ammonia
Blood	Hydrogen peroxide or household bleach
Coffee, tea, food, fruit juices, lipstick	Neutral cleaner in hot water, followed by hydrogen peroxide or household bleach

## **Maintenance Guidelines: Ceramic Tiles**

Caulk cracks and separations of seams adjacent to tile with a top quality flexible caulk, taking care to wipe the tile clean once caulking is complete. Do not use clear silicone-based caulk since it yellows with age and stains easily.

**Glazed Tile Showers:** Use an all-purpose bathroom cleaner. Let stand for five minutes, rinse and dry. Use a mixture of equal parts water and white vinegar or a commercial tile cleaner. For stubborn stains, use chlorine bleach or scouring powder containing a bleaching agent. Let stand four to six hours, then scrub and rinse thoroughly. To remove mildew, use a commercial tile cleaner or chlorine bleach or ammonia. Do not mix chlorine bleach and ammonia!

**Unglazed Tile Walls:** Sponge with a diluted solution of water and soapless detergent. For deep cleaning, use scouring powder paste. Let stand five minutes. Then scour with a brush. Rinse and wipe dry.

1. Never use abrasive cleaners or harsh chemicals or solvents on ceramic tile.
2. Unglazed tiles may need to be sealed on a regular basis.
3. Unglazed tiles may need to be sealed on a regular basis.
4. Never use harsh cleaning agents such as steel wool pads which can scratch or damage the surface of your tile.
5. Do not use a cleaning agent that contains color on unglazed tile. The pores in the ceramic could absorb the color.
6. Do not use a cleaning agent that contains color on unglazed tile. The pores in the ceramic could absorb the color.
7. If continuous staining is a problem on grout joints, use a sealer.

## **Cabinets**

Kitchen, laundry room and bathroom vanity cabinets are all selected for their attractive appearance, durability and ease of care. With proper maintenance, the cabinets will remain serviceable and attractive for many years.

## **Maintenance Guidelines: Cabinets**

**Wood Cabinets:** Wood cabinet tone, grain and color variations are normal and reflect the natural characteristics of real wood.

Clean wood cabinets with the same gentle care you would give any fine wood furniture. A light coat of wax or lemon oil applied once or twice a year will protect the finish and enhance the appearance.

Cabinet-mounted coffee makers are not recommended since the rising steam will damage solid wood and wood veneer, causing fading or delamination. For the same reason, position regular coffee makers out from underneath the upper cabinets and near the front of the counter.

**Laminate Cabinets:** Clean laminate cabinets with soapy cloth or sponge, using a non-abrasive liquid household cleanser for more stubborn stains. There are one-step cleaning products available for laminates that clean, reduce streaking, and leave surfaces polished. As with all cleaning products, carefully follow the manufacturer's instructions.

**Shelves:** Shelves are not designed to hold weight that exceeds 20 pounds per square foot. Keep canned goods, flour, sugar and heavier products on the bottom shelf of the base cabinets. If desired, apply contact paper to shelves to protect against scratches and stains.

**Drawer and Hinge Care:** Check the hinges at least once a year for proper alignment and tightness, using a screwdriver to make necessary adjustments. Check drawers for easy movement and apply a silicone spray to the drawer guides should sticking occur.

**Repairing Nicks and Scratches:** Hardware stores offer color-matching putty, stains, and polymer fillers to cover and repair cabinet nicks and scratches. The homeowner is responsible for fading damage or delamination caused by heat, steam or water intrusion

## **Cable T.V. System**

The homeowner is responsible for contacting the local cable company for the initial hook-up. Roof antennas and/or satellite signal receiving dishes are not allowed in some communities, and you should check with your Homeowner's Association (if applicable) before proceeding with any installation.

## Concrete

**Foundation and Floor Slabs:** In monolithic construction, the floor slab, garage slab, foundations and footings are all poured in concrete at the same time. Most builders use heavily reinforced concrete monolithic slab construction. In some states, in order to prepare the soil for the foundation, a termite spray is applied to the ground prior to pouring the concrete slab. After the first year, it is the homeowner's responsibility to maintain a termite contract.

It is important to understand that concrete is a porous material that will expand, contract, and crack as a result of temperature changes, shrinkage, stress and settlement. Hairline cracks that may appear on foundation walls and be visible on garage floors are common and are usually cosmetic, as opposed to structural. Shrinkage occurs from the normal curing process of concrete that varies with the time of year and the moisture conditions that exist when the concrete is poured. Slab stress and settlement are typically caused by soil conditions and loads such as the weight of the walls. These forces can create a variety of stresses which, in combination with seasonal temperature variations, can cause concrete and masonry foundations to develop non-structural cracks.

**Home Slab and Garage Slab:** Due to the large size of concrete home and garage slabs, shrinkage cracks (less than 1/4 inch wide) are common, and are usually the result of expansion and contraction. These shrinkage cracks are normal and it is best to leave them alone, since attempts to fill the cracks will not stop the expansion and contraction. Cracks in slabs, patios, garage floors, sidewalks and driveways are common and require no additional attention. They are cosmetic in nature and do not affect the integrity of the concrete. Any attempt to repair chips or cracks in concrete will result in product and color variation.

Color variations in concrete are a common occurrence and are beyond the control of the builder or sub-contractor.

### **Maintenance Guidelines: Concrete**

Clean concrete with a solution of five tablespoons of baking soda to a gallon of water. Before using the cleaning solution, wet the floor with clear water and loosen the dirt with a steel brush or scraping blade.

A concrete sealer may be applied to the floor, following the manufacturer's directions, approximately six months after you move in. This will make it easier to clean and will reduce concrete dusting.

**NOTE:** Use of concrete sealer may make the floor slippery when wet

### **A. Concrete Block**

In many homes concrete blocks are used to construct the exterior walls. The concrete blocks are set in place and then reinforced with steel and additional concrete. Concrete block construction requires occasional painting and caulking. Vertical or horizontal shrinkage caused by temperature changes and home settlement are usually cosmetic as opposed to structural and are a homeowner's responsibility.

Additionally, concrete block foundation walls are often covered in stucco in certain areas in the country and vertical or horizontal shrinkage stucco cracks are only cosmetic and can be sealed when the home is painted.

### **B. Stamped Concrete**

Concrete is placed between forms, color hardener is applied to cover the surface then troweled into the surface; color release is applied, then tools are placed to stamp the pattern a minimum of 21 days later, the drive-way or patio will be pressure cleaned and sealed.

### **C. Decorative Concrete Topping (Spray Deck)**

Spray Deck is a decorative type of material that can be applied to a 4" concrete surface. It is generally used around pools and patios.

In most cases, exterior concrete cracks are due to expansion and contraction because of soil movement, temperature variations and pool settling.

**Per manufacturer's instructions:** To remove dirt, mildew, etc., hose down area with water and sprinkle powdered laundry detergent on tile deck and scrub with a soft nylon brush. Let sit five minutes and hose off immediately. Work in small areas so mixture does not dry onto surface. Do not use any abrasive chemicals or pool water which contains chlorine bleach, acid or household bleach. Do not pressure clean deck unless you intend to reseed and stain; it can scar and remove surface.

## **D. Driveways, Sidewalks, Patios, Porches, Steps and Stoops**

In most cases, exterior concrete cracks are due to expansion and contraction because of temperature variations, soil movement and slight home settlement. Driveways are not designed to handle the extreme weight of dual-axle and dual-wheel vehicles.

### **Maintenance Guidelines: Driveways, Sidewalks, Patios, Porches, Steps, and Stoops**

Lawn fertilizer left on the driveway, sidewalks and patios will stain the concrete and cause rust spots. This can be prevented by immediately hosing off the driveway, sidewalk or patio after applying fertilizer.

Water used to irrigate lawns may contain mineral deposits such as iron that can cause driveway, sidewalk and patio staining and mildew. Keep excessive weight such as sand, lumber and moving vans off the driveway to prevent cracking. Rust and grease stains are a homeowner's responsibility.

## **E. Pavers**

Pavers are a concrete product. Minor cracks and chips due to production, transportation, handling and installation will be present. Color variations between pavers may also be present initially but will diminish as they cure.

Efflorescence is a whitish haze that may occur during the first six months. It is a salt deposit brought to the surface by evaporating water. This haze will eventually wear off or it may be removed by using a special cleaner.

### **Maintenance Guidelines: Pavers**

Pavers can be pressure cleaned/washed periodically. Weed killer should be applied to the joints to inhibit weed growth.

**NOTE:** *During pressure washing do not apply pressure directly to the joints as this will remove the sand and possibly dislodge your pavers and cause sinking. Pavers can be sealed eight weeks after installation. They should be pressure washed and allowed to dry several days without rain or sprinklers hitting them prior to sealing.*

Resanding, sealing and weed removal is the homeowner's responsibility.

Do not seal if efflorescence is present. Do not seal if pavers are damp or moist.

## **F. Blacktop Driveways**

"Blacktop" or asphalt driveways require little or no structural maintenance for quite a few years. As the driveway ages, the deep black color will most likely fade and appear light black or gray. The blacktop can be brought back to look like new by applying a seal coat annually or as often as desired. Be sure to follow the manufacturer's instructions when applying the new material. For extensive and structural repairs, we suggest you retain a professional asphalt contractor.

To extend the life of the asphalt driveway, avoid gasoline or oil spills if possible. Clean off any excessive fertilizer that may fall on the driveway as soon as possible to avoid discoloration.

## **Condensation/Mildew**

Condensation, or the appearance of moisture that occurs when warm moist air encounters a colder surface, is most prevalent in new homes, especially during the first year. This is caused by the large quantities of water used to build the new home, from the concrete foundations to the paint on the walls. As this water evaporates, and the drying out process occurs, the moisture takes the form of condensation on interior windows.

Another source of indoor humidity is everyday water usage. For example, a family of four doing laundry, bathing, and using the dishwasher, puts approximately 2 to 5 gallons of moisture into the air every day.

***Window condensation is produced by conditions beyond your builder's control.***

Mildew is a fungus that spreads through the air in microscopic spores. They love moisture and feed on drywall surfaces or dirt. On siding, they look like a layer of dirt. Cleaning mildew from your home is your responsibility. Solutions that remove mildew are available from local paint or home improvement stores. Wear protective eyewear and rubber gloves for this task; the chemicals that remove mildew may be unfriendly to humans.

### **Maintenance Guidelines:**

#### **Condensation/Mildew**

**Ventilation:** Proper ventilation is the safe and steady way to reduce indoor humidity, condensation and mildew.

1. Ensure that the clothes dryer is properly vented to the outside and that the vent is clear of obstructions and lint. Do not push the dryer too far back or the vent hose may become kinked and therefore obstructed. By placing a 2x4 piece of wood behind the dryer, this situation can be prevented.

2. Kitchen, bath and utility exhaust fans should be used to carry moist air outside. Use the fans for short time periods since they exhaust cooler air-conditioned air outside the home.

3. Adjust the registers to maintain even temperatures throughout the home. Do not try to speed up the evaporation process by creating extremely high temperatures in the wintertime. This will cause the house to dry out unevenly, creating cracks and other problems.

## Countertops & Vanity Tops

Kitchen and bathroom counter tops are covered with laminate material or cultured marble.

### **Maintenance Guidelines: Countertops & Vanity Tops**

**Laminate Counter Tops:** Clean laminate counter tops with a soapy cloth or sponge or use a non-abrasive liquid household cleaner for more stubborn stains. There are one-step cleaning products available for laminates that clean, reduce streaking and leave surfaces polished. As with all cleaning products, carefully follow the manufacturer's instructions.

**CAUTION:** *Keep standing water away from the backsplash, side splashes, seams and seal around the sink. These areas are prone to water damage, since excessive moisture will eventually break down the seal and cause swelling or delamination of the countertop. Check seams periodically and recaulk as necessary.*

If countertops or back splashes swell or buckle, it may be due to not maintaining the caulking. This is an important part of your routine maintenance. Joints in laminated surfaces should be periodically caulked to maintain a dryer moisture barrier.

### **A. Cultured Marble Vanity Tops**

Clean cultured marble with a damp cloth and a non-abrasive detergent. When recaulking, use a flexible caulk. A gel gloss or aerosol spray may be used for polishing.

### **Countertop Precautions:**

1. Keep counter top dry at all times.

2. Excessive heat can cause charring, burning, lifting or blistering. Do not place hot irons or burning cigarettes directly on countertop surfaces. Use protective hot pads or trivets under countertop electrical appliances.

3. Always use a cutting board since knives will cut the surface.

4. Steam from an open dishwasher may cause swelling and delamination. Allow time for the dishwasher to cool before opening the door. To further reduce moisture damage, apply a silicone spray to the underside of counter tops, directly over the dish washer and two feet left and right of the dishwasher.

5. Do not use clear silicone caulk, as it yellows with age and stains easily.

### **B. Ceramic Tile Countertops**

Clean countertop tiles with a damp cloth and remove accumulated film with a soapless, nonabrasive detergent or tile cleanser. Use a mild vinegar and water solution to remove grease and soap scum. Keep white tile seams clean by brushing with diluted bleach in a well-ventilated room.

Apply a grout sealant with a small brush to reduce grout staining, taking care to keep the sealant off the tile surface.

Caulk cracks and separations of seams adjacent to tile with a silicone caulk, taking care to wipe the tile clean once caulking is complete. Do not use clear silicone caulk, as it yellows with age and stains easily.

Countertops can be damaged by dropped objects or by forcefully hitting the counter edges.

### **C. Natural Stone Countertops**

**Granite:** Granite is a type of real rock called igneous rock, which means it was once molten and it formed as it cooled deep within the earth. It is extremely hard and durable, and practically scratch proof. It can be highly polished and shiny or finished in a variety of other ways.

Granite countertops are easily cleaned because of low porosity. Wipe up wet spills immediately, especially acidic liquids like citrus juice, alcohol or soft drinks. Never wipe countertops with an acidic cleanser (like vinegar or lemon) or harsh chemicals/abrasive cleaners.

Granite should have a protective sealant applied periodically to prevent staining.

**Quartz:** Quartz, unlike granite, is virtually non-absorbent and scratch-resistant; it requires little maintenance and never has to be sealed or polished. Simply wipe surface with soap and warm water on a regular basis to maintain its beauty and shine.

## D. Solid Surface Man Made Countertops

*Such as, but not limited to, Formica, Corian and Wilsonart Laminate*

Caring for your solid surface countertop is as simple as wiping the surface with a damp cloth. If a stain develops, wipe it away with soap and water. If this does not remove the stain, consult your manufacturer's instructions on products which can be used on your top. Do not expose the surface to harsh chemicals such as paint remover, turpentine, nail polish remover or stove and drain cleaners. If these chemicals come in contact with the surface, immediately wash them off with water, using appropriate safety measures to avoid injury.

Although solid surfacing can be repaired, certain steps should be taken to protect it. Be sure to use a cutting board instead of cutting directly on the surface. Hot pans and heat-producing appliances, when set directly on the countertop, can mar the product's beauty.

## Doors

Your home comes with a variety of doors, which may include interior doors, French doors, louver doors, bi-pass and bi-fold doors, sliding glass doors, exterior doors and garage doors.

### A. Interior Doors

Interior doors expand and contract in reaction to temperature and moisture changes and will be wider in humid summer periods and narrower during dryer winter months.

### **Maintenance Guidelines: Doors**

**Sticking Doors:** Home settlement or damp weather may cause swelling that puts the doors out of alignment. In some cases, this may only be temporary due to seasonal variations, and the sticking will tend to correct itself without any adjustment.

### **If door adjustment is required:**

1. Check hinge screws for tightness.
2. Fold sandpaper around a wooden block and sand the edge that sticks. A small plane can also be used but be careful not to remove too much material from the door. Using a bar of soap on the door top and frame may help.
3. Always paint or varnish sanded or planed areas to protect the wood from future moisture penetration and sticking.

**Door Precautions:** Interior doors are usually hollow core and are not designed to support attachments and hanging accessories. Hanging heavy items on doorknobs, or at the top of a door, can damage hardware and hinges. These doors are also undercut to allow air movement.

**Slamming:** Slamming doors can damage both doors and jambs and can even cause cracking in walls. Teach children not to hang on the doorknob and swing back and forth; this will loosen the hardware and cause the door to sag.

**Shrinkage:** Use putty, filler or latex caulk to fill any minor separations that develop at mitered joints in door trim. Follow with painting. Panels of wood doors shrink and expand in response to changes in temperature and humidity. Touching up the paint or stain on unfinished exposed areas is your home maintenance responsibility.

### B. Bi-Fold and Bi-Pass Doors

Keep the door tracks free of paint and dirt and apply a small amount of silicone spray to the guide edges of the tracks.

### C. Sliding Glass Doors and French Doors

Keep sprinklers away from sliding glass doors and French doors when watering the lawn. Sliding glass doors have been sealed against water, but occasionally, high winds and driving rains can create a vibration that causes some leakage. Neither this, nor the water that accumulates in the tracks, can be prevented. This is also true for French doors.

The sliding tracks should be kept clean and free of debris. Rollers should be lubricated and adjusted if needed to maintain a smooth operation.

Clean glass with a spray glass cleaner and wipe frames with sudsy water and a soft cloth. Periodically clean the bottom of the door track, and check to ensure that drain holes are clear of obstructions. To keep the doors moving freely, apply a silicone spray to the tracks. Do not use oil, which may cause premature deterioration of the rollers.

In some cases, the glass is tinted to help block the rays of the sun. If you feel you need solar protection film on your glass, it is important to note that **ALL SOLAR FILM MUST BE APPLIED TO THE INSIDE PANE OF GLASS**. Otherwise, heat build-up between the layers of glass will cause the glass to crack.

#### D. Exterior Doors

An exterior door that is properly aligned, fitted, weather-stripped and maintained will help control energy costs. Exterior doors are often steel-clad or fiberglass to prevent warpage and to maximize insulation. An exterior door will warp to some degree, due to temperature differences between the inside and the outside surfaces. Warpage should not exceed 1/4" measured diagonally from corner to corner.

**NOTE:** *Wood exterior doors should be checked every six months for signs of weathering and repainted as necessary.*

**Painting:** Steel-clad or fiberglass doors are maintenance-free and require little attention except for painting and upkeep from dents and scratches.

**Weather stripping:** Weather stripping on exterior doors helps maintain the home's energy efficiency, preventing the loss of conditioned air, and reducing the infiltration of outside air. Weather stripping must remain in place to operate effectively.

1. Replace weather stripping that becomes loose or damaged.
2. Prolong the life of vinyl and rubber weather stripping by applying a silicone spray.
3. The sweep weather stripping at the bottom of the door may require replacement from time to time. To replace, remove the sweep and match with a replacement available at any hardware store.

4. To raise or lower the threshold, adjust the screws on the wood or metal portion of the threshold. Keep threshold caulked at all times.

5. Keep sprinklers away from doors.

## Door Hardware, Locks, Hinges, and Keys

The brass door locks, door handles, hinges and stoppers used throughout the home are exposed to both inside and outside elements, pollution, extreme elements, and common everyday use. This may cause them to discolor or become pitted. The manufacturer does not guarantee the finish of any product. Clean these with a damp cloth and do not use abrasive cleanser or solvents. Periodic polishing, following manufacturer's recommendations, will help maintain the original luster and appearance. Do not use brass polish on lacquered brass parts or fixtures.

**Locks:** Lubricate door locks with graphite or other waterproof lubricant. Avoid oil, as it will gum up.

**Failure to Latch:** If a door will not latch because of minor settling, you can correct this by making a new opening in the jamb for the latch plate (remortising) and raising or lowering the plate accordingly.

**Hinges:** You can remedy a squeaky door hinge by removing the hinge pin and applying a silicone lubricant to it. Avoid using oil, as it can gum up or attract dirt. Graphite works well as a lubricant but can create a gray smudge on the door or floor covering beneath the hinge if too much is applied.

**Keys:** Keep a duplicate privacy lock key where children cannot reach it. The top edge of the door casing is often used as a place to keep the key. A small screwdriver or similarly shaped device can open some types of privacy locks.

Your interior door locksets can loosen over time. If you notice excessive play in the lockset, we recommend tightening the screws located in the cover plate. If the doorknob has become inoperative, it could mean that the interior mechanism has slipped out of place.

Remove the knob, realign the interior mechanism, reset the knob, then tighten the exterior screws. Should a lock be hard to operate, apply a graphite lubricant to the keyhole and lock mechanism. This will usually help the lock to operate more smoothly.

## Electrical System

The electrical system in your home is designed for safe, trouble-free service and meets both local and national electrical code requirements. Any additional alteration or modification to the original electrical system installation will void all applicable warranties.

### **Maintenance Guidelines: Electrical System**

**Electrical Safety Cautions:** Do-it-yourself electrical wiring, improper electrical wiring, and improper electrical repairs endanger the lives of your family and jeopardize your homeowner's insurance in the event of fire or electrical injury. Always use a licensed electrician to make electrical repairs, adjustments and additions.

**Electrical Storm Caution:** It is recommended that you unplug television sets, computers and telephones during electrical storms.

**Power Failure:** If the electrical power goes out, check first to determine if neighbors are also without power, and if so, contact the utility company. Before attempting to reset the circuit breakers, check power has been restored to the area. If neighbors have power, check the main circuit breaker in the panel box.

Be aware that not every electrical power problem is due to problems within the home's electrical system. Utility companies experience a variety of situations that effect power supplies, including power surges and interruptions, peak overload periods, and even total shutdowns.

**Electric Meter:** The utility company installed an electric meter to measure your electric usage for billing purposes. Their invoice is based on kilowatt-hours used over a given time period, with a kilowatt-hour being the energy expended by 1000 watts for one hour. Should you have any questions about the meter functions, please contact the customer service department at the utility company.

**Circuit Breakers:** Electrical wiring and appliances are protected by circuit breakers to stop circuit overloading. The main circuit breaker is in the electrical panel box, and if tripped for any reason, entirely cuts off all electricity to the house. The smaller circuit breakers within the panel box control appliances, wall switches, lighting, and the HVAC system, and each switch should be clearly marked as to what it controls. Do not tamper with the electrical service entrance cable that provides power to the service panel.

### **Circuit Tripping Causes and Remedies:**

Thunderstorms, lightning and power failures can cause circuit breakers to trip. If only your home is affected, try to reset by switching the breaker to full "OFF" then back to full "ON" position. If this does not reset the breaker, or if the breaker continues to trip, do not continue resetting the breaker as this can damage the panel box, wiring, or the appliance that it controls. Call a licensed electrical contractor for a service inspection.

Overloaded circuits can also cause tripping. This occurs when too many appliances are used on one circuit. To reduce the load, remove plugs of appliances that may cause the overloading, then reset the breaker as described above. If you install a microwave oven or other appliances that require large electrical loads, you may need a licensed electrical contractor to add wiring to accommodate the load.

**Outlets and Wall Switches:** If an electrical outlet does not work, make sure that the outlet is not controlled by a wall switch. If the outlet still does not operate, contact an electrical contractor.

**DO NOT PLUG A REFRIGERATOR OR FREEZER INTO A GFCI CONTROLLED OUTLET. THERE IS A GOOD CHANCE THAT IF THE GFCI TRIPS, YOUR FOOD WILL BE RUINED BEFORE YOU NOTICE THE PROBLEM.**

**Ground Fault Circuit Interrupters:** GFCI electric outlets prevent electrical shock, and are installed in kitchens, bathrooms, garages, and exterior areas where water may be present. GFCI receptacles are sensitive to power surges and interrupt power under certain conditions to prevent injury.

GFCI outlets are often wired in a series. For example, the garage GFCI outlet controls the bathroom, and may possibly control other outlets throughout the home. In other words: if the electrical outlet in the bathroom is not functioning, check the GFCI in the garage. Also be aware that some homes have multiple GFCIs, so inspect and reset the affected outlet. If a GFCI receptacle is not functioning, press the "RESET" button on the wall plate to restore proper operation. If that does not work, check and reset the circuit breaker in the panel box first, then press the GFCI Reset button. If the outlet still fails, it may indicate a short in the appliance. If other appliances will not operate, an electrician should be contacted and the GFCI replaced.

To test GFCI's, press the "TEST" button on the receptacle. The outlet should not perform. To reset, press the reset button.

### **Arc Fault Circuit Interrupter**

As of January 2002, The National Electrical Code requires all 15 and 20 ampere outlets installed in bedrooms to be protected by an Arc Fault Circuit Interrupter (AFCI) in addition to standard circuit breakers in your home.

There is a difference between an AFCI and a standard 15 or 20 ampere circuit breaker. The standard circuit breaker is made to detect overheating due to overloading on the circuit, not due to electrical faults caused by electrical low-level arcing which the AFCI is designed to detect. A standard breaker may not trip if not enough electrical current has flowed through to cause heat buildup within the breaker. The AFCI can sense when an arc or short circuit is about to spark and quickly trip the circuit.

### **Arc faults are typically the result of:**

1. Worn electrical insulation
2. Damaged plug-in appliance cords
3. Punctured electrical cable from errant screws and nails
4. Attaching electrical cable too tightly to the studs
5. Loose electrical connections

The AFCI reset button is generally located in or near the circuit breaker panel box and should be checked regularly. If the AFCI trips after it has been reset, you should call a professional electrician.

Pre-wired for Telephones: Most homes are pre-wired for telephones. If you experience problems with the telephone system you should contact your local phone company. If the telephone company states that there is trouble in the house wiring and your house is less than one year old, please call your builder.

## **Lighting Fixtures**

Interior and exterior lighting fixtures require periodic Homeowner's Maintenance to preserve the finish. Carefully review and follow the instructions if provided for these fixtures.

Interior and exterior fixtures will tarnish, and the manufacturer does not warrant the finish. Always turn the power off at a wall switch or circuit breaker before cleaning any electrical device. The danger of a severe shock will still exist if the device is turned off with a built-in switch.

Do not use indoor bulbs in outdoor lighting fixtures if the bulb is to be exposed to the weather. Do not use light bulbs with a higher wattage than the maximum wattage stated on the light fixture.

## **Smoke Detectors**

The smoke detectors in your home are pre-wired, per electrical code requirements, into the main electrical system. In case of electric failure, the smoke detector is backed up with a 9-volt battery.

### **Maintenance Guidelines: Smoke Detectors**

Test the detectors and clean and vacuum the openings of the smoke detectors every six months. Visually inspect the clear button on the test switch to see that the indicator light is glowing. To test the alarm, press the Test-button for about ten seconds, or until the horn sounds lightly. Do not use an open flame to test the detector.

The unit will emit a low-frequency beeping noise if a malfunction or power failure occurs or if the battery is low. Change the 9-volt battery every 6 months to ensure proper operation.

## Security System & Intercom

Some homes are equipped with security systems and/or intercom, and their operating instructions and warranty information are contained in their respective manuals and product literature.

## Exterior Wall Finishes

Exterior finishes are applied once the exterior framing and/or concrete block is complete. The exterior of your home may be finished with stucco, brick, siding and/or stone.

### A. Stucco

There are two types of stucco application. One is applied over concrete block construction, while the second is applied over wood framed walls with wire lath attached.

Stucco requires very little maintenance other than painting and caulking. In certain areas of the country, concrete blocks are used to construct the majority of exterior walls. The concrete blocks are set in place with mortar, and then reinforced with steel and additional concrete. The stucco finish on concrete block construction requires occasional painting and caulking.

Stucco vertical or horizontal shrinkage cracks caused by temperature changes and/or home settlement are usually cosmetic and very unlikely to be structural defects.

Normal shrinkage cracks that occur in stucco should be filled with a flexible masonry caulk. The cracks should then be painted with a good acrylic or elastic acrylic paint.

**Rust Spots in Stucco:** Stucco is made from mortar, water and mineral free sand. Sand can sometimes contain a spec of iron which will bleed through the paint after some time, this is normal. Simply scrape out the rust spot, fill with latex caulk and paint.

### B. Brick

Brick is used extensively throughout the United States. It is probably the lowest maintenance finish of all home exterior finishes.

The mortar between the bricks may require some tuck-pointing (filling in) as your home ages. The weep holes in the brick are there to allow moisture out. Do not fill these holes or allow landscaping material to cover them. Be aware there may be some mortar joint cracks, commonly referred to as "stair step cracks" that are normal due to expansion and contraction of exterior walls.

**Efflorescence:** A white powdery substance that may appear on the exterior walls is called efflorescence. It is normal and is composed of water-soluble salts, originally present in masonry materials that are brought to and deposited on the surface when water evaporates. Most efflorescence can be removed with a stiff scrub brush, water and vinegar.

### C. Stone Veneer

Slight variations in size, color and placement create the textural interest that contributes to the look of a stone exterior. Minor stone chipping, cracking and cement shrinkage are normal due to weather conditions such as rain, sun and temperature.

### D. Siding

Siding expands and contracts in response to changes in humidity and temperature. Slight waves are visible in siding under certain weather conditions; this cannot be entirely eliminated. Wood or wood-product siding will require routine refinishing. The timing will vary with climatic conditions.

### E. Soffit and Fascia

The aluminum soffit and fascia (*where applicable*) have a baked enamel finish that does not require painting. Wood and stucco fascia do require painting and caulking. The soffit vents are located under the roof overhang. The fascia is used behind gutters and to cover gable trim boards.

---

## Solutions to Common Exterior Finish Problems

---

<b>PROBLEM</b>	<b>LIKELY CAUSE</b>	<b>SOLUTION</b>
Dents in soffit or fascia.	Abusive treatment.	Replace panel.
Side blows off.	Strong winds under 54 miles per hour.	Call during first year for inspection.
Side blows off.	Strong winds over 54 miles per hour.	Act of God. Review homeowner's insurance policy.
Nicks or deep depressions in wood siding.	Abuse or accidents.	Caulk and repaint as soon as possible.
Dirty siding.	Adverse weather conditions and soiling.	Periodic hosing. See manufacturer's recommendations.
Siding has dirty, streaked appearance.	Mildew and fungus growth.	Apply commercial mildew cleaner following manufacturer's direction.
Cracking/peeling of painted surfaces.	Normal aging and weathering.	Clean and sand surface, then prime and repaint.
Gaps at joints in wood trim.	Normal caulk and filler shrinkage.	Re-caulk or fill.
Sap on exterior trim.	Wood drying out.	Sand, prime and paint.
Efflorescence on masonry finishes.	Crystallized soluble salts.	Scrub with water, vinegar and a stiff brush.
Cracks or stairstep cracks in masonry finishes.	Normal home settlement.	Seal cracks with a flexible masonry caulk.

## Exterior Home Maintenance – How to Use a Pressure Washer

Over time, the siding, stucco, brickwork, stone, and other exterior finishes of your house accumulates dirt, grime and mildew. Using a pressure washer to clean the exterior of your house can clean and refresh the surfaces. Pressure washers have high-pressure sprays and will work much better than the average garden hose.

### Maintenance Guidelines: Pressure Washers

1. Choose the right nozzle for the pressure cleaner. Some nozzles could damage your home's exterior finish such as painted stucco.
2. Soap and cleaning solutions may be harmful to some exterior surfaces. Never allow the soap or solution to dry on the exterior finish before rinsing off.
3. Before you begin pressure washing, always test the spray in an inconspicuous area of the house.
4. Start pressure washing at the top of the house working towards the bottom.
5. Do not point the high-pressure spray directly at electrical boxes or windows.
6. Make sure you protect your eyes. Debris may fly from the house while you are spraying.

## Fireplaces

In most cases, builders use a pre-fabricated fireplace that is delivered to the home site and then installed with a screen and glass doors. Do not burn pressure-treated wood, scrap lumber, Christmas trees, trash, cardboard, plastic or any flammable liquid such as gasoline. Burning these materials may cause brick and flue liners to crack.

### Maintenance Guidelines: Fireplaces

**Fireplace Equipment:** A set of fireplace tools will help you handle logs, stoke the flames and shovel out cold ashes.

**Fireplace Inspections:** A clean, unobstructed fireplace and chimney are important for safe fireplace operation. Have a fireplace chimney company inspect the fireplace and chimney annually for soot build-up and appropriate cleaning. Inspect the hearth and liner for loose or cracked firebrick.

**Fireplace Inspections:** A clean, unobstructed fireplace and chimney are important for safe fireplace operation. Have a fireplace chimney company inspect the fireplace and chimney annually for soot build-up and appropriate cleaning. Inspect the hearth and liner for loose or cracked firebrick.

## Gas Fireplace

If you have a gas fireplace, supplying the source for the gas is usually the homeowner's responsibility.

A slight delay between turning the switch "on" and the flame ignition is normal. The flames should ignite gently and silently. If you notice any deviation from this and/ or any gas smell, immediately shut off the switch and report it to the gas company.

Excessive winds can cause a downdraft which can blow out the pilot, requiring you to relight it before using the fireplace.

The exterior vent cover for a direct-vent gas fireplace becomes extremely hot when the fireplace is operating.

### Maintenance Guidelines: Gas Fireplace

Close the damper and cold air vent when not using the fireplace. Leaving this open is equivalent to having an open window in the house. If the fire is still burning, but you are finished enjoying it, use glass doors to prevent heated air from being drawn up the chimney until your damper can be closed.

**Caution on the use of glass doors:** Do not close them over a roaring fire, especially if you are burning hard woods (such as oak or hickory) because this could break the glass. Also, when closing the doors over a burning fire, open the mesh screens first. This prevents excessive heat build-up on the mesh, which might result in warping or discoloration.

### **Checklist for Safe Fireplace Use:**

1. Open the flue damper and outside air vent fully, and visually check that the flue is not obstructed. Clear obstructions and ashes.
2. Use a steel or cast-iron grate to elevate the wood above the fireplace brick. Do not build fires on the fireplace floor.
3. Place crumpled, non-colored newspaper under the grate.

4. Place crumpled, non-colored newspaper under the grate.
5. Add kindling (small wood chips and twigs) on the grate over the newspaper.
6. Place three small legs in a pyramid arrangement at the back of the firebox, providing air spaces between logs.
7. Preheat the flue by lighting a piece of newspaper onto the logs, making sure that the smoke is being carried up the chimney.
8. Ignite the newspaper under the kindling.
9. Use seasoned hardwood for a long-burning, smoke-free fire. Store firewood outside as it may harbor insects.
10. Do not build large fires.
11. Keep damper open and screen or glass doors closed throughout the life of the fire.
12. Close damper the following day when the fire is completely out. Periodically remove ashes from previous fires and place them outdoors in a metal container.

## Flooring: Carpet, Tile, Hardwood & Resilient

Your home may be finished with a variety of flooring materials, including carpet, vinyl, hardwood and ceramic tiles.

### A. Carpeting

The carpet is durable and requires minimal care. Color variations and shading may be noticeable and depend upon the surface texture and pile fiber of the carpet.

#### **Maintenance Guidelines: Carpeting**

Frequent vacuuming and immediate stain removal are primary carpet care steps. Follow manufacturer's instruction when using carpet cleaners.

A tuft may be lifted above the surface during normal vacuuming. Do not pull the tuft; snip it with scissors to the length of the other tufts. Color fading and spots caused by sunlight are normal. Minimize fading by using draperies to reduce incoming sunlight. Some colors may fade faster than others.

Change filters in your heating and air conditioning systems on a regular basis or when dirty. Dust, pollen and smoke will settle on your carpets and increase staining and soiling.

**Cleaning:** You can add years to the life of your carpet with regular care. For spills, blot immediately with a dry rag; avoid rubbing which can cause damage. Carpet wears out because of foot traffic and dirt particles that get trampled deep into the pile beyond the suction of a vacuum. The dirt particles wear down the fibers like sandpaper and dull the carpet.

The most important thing you can do to protect your carpet is vacuum it frequently. Vacuum twice each week lightly and once a week thoroughly. Heavy traffic areas may require more frequent cleaning. A light vacuuming is three passes; a thorough job may need several passes. A vacuum cleaner with a beater-bar agitates the pile and is more effective in bringing dirt to the surface for easy removal.

Vacuuming high-traffic areas daily helps keep them clean and maintains the upright position of the nap.

**Stains:** No carpet is stain proof. Although your carpet manufacturer designates your carpet as stain-resistant, some substances may still cause permanent staining.

**Cleaning Stains:** Wipe spills and clean stains immediately. First, scoop-up or blot as much of the spill as possible from the carpet; avoid rubbing. Using a rag, blot from the edges toward the center of the stain until dry. Test stain removers on an out-of-the-way area of the carpet, such as in a closet, to check for any undesirable effects. Have your carpet professionally cleaned regularly, usually once a year

For asphalt, butter, chocolate, cooking oil, furniture polish, grease, food, lipstick, mascara, oil, shoe polish or tar, apply a small amount of dry-cleaning fluid (*non-oil type commonly used for spot removal from garments*) to a dry cloth towel and blot. Repeat and blot until the spot is dry.

For ice cream, latex paint, excrement, mayonnaise, milk, vomit and white wine, apply a small amount of detergent, cleaner, or solvent to a dry cloth towel and blot. Repeat and blot until the spot is dry.

For fruit drinks, berries, blood, coffee, fruit juice, ketchup, mustard, soft drinks, tea and red wine mix 1/2 cup household hydrogen peroxide with one teaspoon clear ammonia and dampen the spot with a small amount of the mixture. Let stand for two to three hours under a weighted sheet of plastic wrap. Blot with paper towels until dry. Apply a little undiluted white vinegar after stain is removed.

**NEVER APPLY DETERGENTS OR STAIN REMOVER DIRECTLY TO CARPET!**

This could cause permanent discoloration. For recommended cleaners and solvents, call the fiber producer. When a stain reappears after cleaning, it means all the stain and cleaners were not removed completely. Recleaning is necessary. Always rinse your carpet thoroughly to remove any detergent residue.

**Burns:** Take care of any kind of burn immediately. First snip off the darkened fibers. Then use a soap-free cleaner and sponge with water. If the burn is extensive, talk with a professional about replacing the damaged area.

**Crushing:** Furniture and traffic may crush a carpet's pile fibers. Frequent vacuuming in high-traffic areas and glides or cups under heavy pieces of furniture can help prevent this. Rotating your furniture to change the traffic pattern in a room promotes more even wear. Some carpets resist matting and crushing because of their level of fiber, but this does not imply or guarantee that non matting or crushing will occur. Heavy traffic areas such as halls and stairways are more susceptible to wear and crushing. This is considered normal wear.

**Fading:** Science has yet to develop a color that will not fade with time. All carpets will slowly lose some color due to natural and artificial forces in the environment. You can delay this process by frequently removing soil with vacuuming, regularly changing air filters in heating and air conditioning systems, keeping humidity and room temperature from getting too high, and reducing sunlight exposure with window coverings.

**Filtration:** If interior doors are kept closed while the air conditioning is operating, air circulation from the closed room flows through the small space at the bottom of the door. This forces the air over the carpet fibers, which in turn act as a filter, catching particulate pollution. Over time, a noticeable stain develops at the threshold.

**Rippling:** With wall-to-wall carpeting, high humidity may cause rippling. Prolonged or extreme cold and heat can also cause rippling. If the carpet remains rippled after the humidity has left, have a professional re-stretch the carpeting using a power stretcher, not a knee kicker.

**Seams:** Carpet usually comes in 12-foot widths, making seams necessary in most rooms. Visible seams are not a defect unless they have been improperly made or unless the material has a defect, making the seam appear more pronounced than normal. The more dense and uniform the carpet texture, the more visible the seams will be.

Carpet styles with low, tight naps result in the most visible seams. Seams are never more visible than when the carpet is first installed. Usually with time, use and vacuuming, the seams become less visible. You can see examples of how carpet seams diminish after they have been vacuumed and have experienced traffic in the model homes.

**Shading:** Shading is an inherent quality of fine-cut pile carpets. Household traffic causes pile fibers to assume different angles; as a result, the carpet appears darker and lighter in these areas. A good vacuuming, which makes the pile all go in the same direction, provides a temporary remedy.

**Shedding:** New carpeting, especially pile, sheds bits of fiber for a period of time. Eventually these loose fibers are removed by vacuuming. Shedding will usually occur more with wool carpeting than with nylon or other synthetic.

## **B. Ceramic Tile Floors**

Ceramic tile is easy to maintain and impervious to water. The grout joints are not waterproof and require special attention to prevent water seepage. Cracks appearing in grouting of tile joints or at junctions with other materials (i.e. baseboards) are the responsibility of the homeowner.

### **Maintenance Guidelines: Ceramic Tile Floors**

Glazed and unglazed tile floors — Vacuum regularly to remove gritty particles. Damp mop using a solution of water and soapless detergent. If stained, use scouring powder paste. Let stand five minutes, brush and scrub. Rinse and dry.

1. Never use abrasive cleaners or harsh chemicals or solvents on ceramic tile.
2. Unglazed tiles may need to be sealed on a regular basis.
3. Wipe spills immediately.

**NEVER USE HARSH CLEANING AGENTS, SUCH AS STEEL WOOL PADS, WHICH CAN SCRATCH OR DAMAGE THE SURFACE OF YOUR TILE.**

### C. Marble & Granite Floors

Marble and granite floors are natural products with a wide range of stain resistance. Marble is more porous than granite. Common household liquids such as orange juice, nail polish remover, shampoo, and even water can cause serious stains in certain kinds of marble. Granite, on the other hand, is highly stain resistant.

#### **Maintenance Guidelines: Marble & Granite Floors**

1. Only use warm water.
2. Never use vinegar as it damages marble.
3. Wring out excess moisture from towels or mops immediately followed by a dry towel.
4. Always dry floors as they can spot easily.
5. Clean spills immediately.
6. Natural pH breathable sealers are recommended on a regular basis for both marble and granite.

## Grout Stain Removal Guide

Stain	Removal Agent
Grease and fats	Soda and water or commercial spot-lifter
Inks and dyes	Household bleach
Mercurochrome	Ammonia
Blood	Hydrogen peroxide or household bleach
Coffee, tea, food, fruit juices, lipstick	Neutral cleaner in hot water, followed by hydrogen peroxide or household bleach

### D. Hardwood Floors

Most hardwood floors are pre-finished at the factory with a baked-on wax coating or a urethane coating. Wood floor tone, grain and color variations are normal and reflect the natural characteristics of real hardwood.

Some squeaking or separating of hardwood floors is normal and is caused by seasonal weather and humidity changes. It is normal to expect surface nailing to occur around the perimeter area of prefinished hardwood floors, and around any repair areas.

Cupping or crowning are normal and occur from gaining or losing moisture on one side faster than the other. Neither the builder nor the manufacturer can stop this from happening. It is also due to natural growth rings in the tree and the part of the tree that has been used. In some instances, the cupping and crowning action may loosen nails or adhesive. The only way to control this occurrence is to try to keep your home at an even temperature and moisture level.

#### **Maintenance Guidelines: Hardwood Floors**

Prior to cleaning your hardwood floors, carefully read and follow the manufacturer's instructions and recommendations. Use entrance rugs or mats to protect wood flooring from dirt and water spots. Do not use rubber backed mats as they will remove the finish. Mop water spills immediately. Do not set potted plants directly on a hardwood floor as moisture can leak through and cause permanent staining and warpage.

Attach furniture protectors to the bottom of furniture legs to protect the hardwood flooring from scuffing and surface damage. High-heeled shoes and constant moving of chairs can damage hardwood floors.

Extra care is required to keep hardwood floors dry and to promptly mitigate any unusual water intrusion that could occur.

### E. Luxury Vinyl Flooring and Vinyl Flooring

Luxury vinyl flooring is a type of flooring made from synthetic materials that come in planks or tiles. It's designed to be durable, waterproof, and look like wood or stone. Before cleaning a vinyl floor, read and follow the manufacturer's cleaning and care instructions. Do not wax a "no-wax" floor.

## **Maintenance Guidelines: Vinyl Floors**

Luxury vinyl is water-resistant but not waterproof, so it's important to avoid soaking the surface. **Stick to a damp mop and a manufacturer-approved vinyl floor cleaner for optimal results.** Excess water can seep into the seams, leading to potential damage over time. Avoid using a steam mop.

## **Maintenance Guidelines: Wood or Laminate Floors**

**General Cleaning:** Use a clean dust mop (be sure there is no residue from polishes or cleaners used on other types of flooring).

**Damp Mopping:** Use a cotton or cloth mop and clear, warm water. For heavier cleaning, use a solution of one-cup household vinegar to one gallon of warm water, or 1/4 cup household ammonia to one gallon of warm water. Only dampen the mop slightly to avoid leaving water marks. Oily soaps can leave residue on wood floors that can deteriorate the wood sealant over time.

**Stain Removal:** To remove scuff marks, crayon, magic markers, glue haze from a newly installed floor, use acetone or denatured alcohol and a soft cloth.

## **Framing & Carpentry**

**Wall Framing:** Wood and/or metal studs are set vertically on 16-inch or 24-inch centers.

**Roof Framing:** Roof framing uses a pre-engineered truss system or hand framed roofing that supports the weight of the roof and can be used in combination with conventional ceiling and roof framing. The trusses are delivered to the building site by truck, and then placed and secured into position on the home using a crane.

**Roof Sheathing:** Roof sheathing covers and serves as a base for the roofing materials.

As the wood in your home dries, normal shrinkage will occur that causes settlement. While every home has certain degrees of settlement, not all settlement is severe enough to require repair. Natural shrinkage and swelling will cause small cracks, chips and splits. These are acceptable under industry standards. You may also hear noises that are caused by expansion and contraction due to temperature fluctuations in the attic, ceilings and walls of your home.

**Insulation:** Insulation is placed wherever there is likely to be a difference between interior and exterior temperature or humidity in the floors, ceilings, exterior walls and the attic.

Flexible insulations, in the form of cellulous or blown insulation or fiberglass blankets, are commonly used in walls, floors, ceilings and around air ducts. Plastic foam may be used for spot insulation around windows and doors, pipe openings and other air leakage points.

**R-Value:** This is an insulation measurement. The higher a material's "R-Value" number, the more effective it is as an insulator. Different parts of the home have different insulation standards.

## **Garage Doors**

Garage doors with remote openers can be operated manually by pulling the release cord at the top of the garage door near the track, and then lifting the garage door open. If minor garage door adjustments are required, contact an authorized repairman.

**NOTE:** *Photo cells are not designed to be waterproof, and care must be taken when pressure cleaning or hosing out the garage. If the photo cells get wet, they may not allow the door to close.*

Garage overhead doors cannot be airtight. Some light will be visible around all the edges. Severe weather conditions may result in some precipitation entering around the door.

## **Interior Walls & Ceilings**

Your home has two types of walls: load-bearing and non-load-bearing.

1. Any alteration of load-bearing walls may reduce the strength of the structure by altering its unit load capacity, its load-bearing or support capacity.

2. Interior wall construction begins with the placement of studs set vertically at specified intervals. Then the drywall is screwed and/or nailed to the studs.

**Drywall:** Drywall is screwed to the studs of the ceiling and wall surfaces. The seams where sheets of drywall come together are taped, spackled with a joint compound, allowed to dry and then sanded to prepare them for finishing.

Acceptable building standards are that slight "imperfections" such as nail pops, seam lines and cracks not exceeding 1/8" are common in drywall installations

However, obvious defects or poor workmanship resulting in excess compound in joints, trowel marks and cracked corner beads are not acceptable and must be noted prior to closing. Both nail pops and small drywall cracks are simple to repair.

## **Drywall Nail Pops and Crack Repair**

### **Instructions:**

1. Reset the protruding nail slightly into the gypsum board surface or remove it entirely. Place another drywall nail two inches above or below the popped nail, and gently hammer it slightly below the paper surface. Then cover the area with spackling compound, allow to dry, sand smooth and then refinish the surface.
2. For drywall joint cracks, press a small "V"-shaped indentation using the back of a putty knife along the length of the crack, about 1/8" deep and 1/8" wide. Spackle, sand and refinish as with nail pops.
3. To prevent cracks wider than a 1/4" from reopening, first apply the spackling compound over the crack with a strip of drywall tape, add another top layer of spackling, feathering the edges well; sand to a smooth finish, then refinish.
4. Deep scrapes and indentations on drywall surfaces can be filled with two or three applications of spackling compound. Allow it to dry thoroughly, and sand between each application.
5. Touch-up painting of repaired areas will not blend perfectly with the original wall paint.

**Interior Trim and Moldings:** Homes are built with various moldings such as floor moldings, door casings and other wood trims. Some separation of wood trims and moldings is normal and caused by home settlement, plus shrinkage or expansion due to dryness or humidity.

### **Maintenance Guidelines: Interior Walls & Ceilings**

If the baseboard trim come loose, re-nail the baseboard into the proper position. For moldings, it is better to wait for several months to see if settlement will bring the pieces back together naturally. If not, a separation at corners or seams can be patched with wood filler and then refinished to match the existing molding.

Wood trim shrinkage occurs during the first two years or longer, depending on temperature and humidity. Wood will shrink more across the grain than lengthwise.

Wood shrinkage can result in separation at joints of trim pieces. All lumber is more vulnerable to shrinkage during the heating season. Maintaining a moderate and stable temperature minimizes the effects of shrinkage. You can usually correct this with caulking and touch-up painting.

When re-nailing baseboards, drive in another nail close to — but not exactly in — the existing nail hole. Fill the old nail hole with putty and touch up with paint as needed. If the base shoe (small trim between base molding and the floor) appears to be lifting from the floor, this is probably due to slight shrinkage of the floor joists below. Again, you can correct this condition by removing the old nails and re-nailing. You may prefer to wait until after the first heating season to make any needed repairs.

## **Landscaping, Grading, Lawn, Shrubs, and Sprinklers**

Landscaping plans are generally designed by a landscape architect and approved by local officials. The home may be part of the entire community's landscape master plan and therefore cannot be individually modified. Check with your builder before doing any extensive landscaping changes.

### **A. Grading**

The drainage plan for your community was designed by engineers and approved by the various authorities having jurisdiction. Storm water management is a critical part of the community design. The yard is carefully graded to direct storm water away from the house into areas where it can soak away or eventually flow into the community storm water drainage system.

After heavy rain, it is normal to see significant areas of standing water. This is a deliberate part of the approved drainage design; it allows water to enter the drainage system slowly and helps to limit the entry of nutrients, fertilizers, etc., into the interconnected fresh-water system. After normal, heavy rain, water should not be standing on paved areas after 48 hours. Swales and drainage areas may be permanently wet, particularly in times of heavy rain or melting snow.

### **Maintenance Guidelines: Grading**

Over time, the grade around the house can settle. If this occurs, spread additional soil or sand in the depressions to raise and re-establish the grade. Be sure the grade slopes away rather than towards the house.

To prevent erosion and ponding of water:

1. Do not alter the soil grade.
2. Keep water ditches or swales open and free of leaves and debris. Do not build sheds, hot tubs, decks, fences, pools, or gardens in the swales; otherwise, water may not flow properly through the swale.
3. Direct water run-off away from the home to prevent washouts. Reposition splash blocks if they are moved.
4. Do not allow sprinklers to wet the house or form puddles near or against the foundation.

## **B. Lawn**

In new homes, the yard is graded, and the landscape contractor removes debris and rakes the ground surface prior to installing sod or grass seed.

### **Maintenance Guidelines: Lawn**

The future beauty of your yard depends on the care and attention you provide. The builder can not be responsible for homeowner neglect or improper landscape maintenance. The following suggestions should make the job easier.

**Watering:** Sod requires constant moisture until the second mowing. If allowed to dry out, the sod will shrink and gaps will appear between the sections. If this occurs, the homeowner will need to repair these areas.

For the first six weeks, water the lawn for 30 minutes once each day in the morning. Watering may be reduced after the second mowing to every other day for the next eight weeks. When using the sprinkler system, check to see if you are leaving footprints. If so, the area has been over watered. Remember, too much water is just as bad as not enough.

**Fertilizing:** Fertilizer should be applied a minimum of three times a year for turf. In the winter months two applications are necessary, and one should be a weed and feed. In the summer months one application should be applied. Spray insecticide every other month. Do not spray immature grass with chemicals to kill weeds. The best approach is to use pre-emergent weed control when grass is stronger and more mature.

Be aware that sod, when initially laid, will occasionally go into shock and turn brown. The sod is not dead, and you should continue to water it.

Extremely hot or cold weather or above average rainfall will affect these instructions.

**Mowing:** Mow new grass when it attains a height of four to six inches. Do not mow if the ground is soggy. Set the mower height at approximately three inches. Be sure the mower blades are sharp to avoid tearing the grass.

## **C. New Shrub and Tree Care**

The landscaping around your home has been planned by a professional landscape designer. All trees and shrubs are nursery grown, and a landscape contractor handled the initial planting. The homeowner is responsible for maintaining the new plantings. The type of tree or shrub will dictate the specific care needed; check with your local gardening center.

### **Maintenance Guidelines: New Shrub and Tree Care**

**Watering:** It is extremely important that new plants and trees be watered once a day for the first month, for one to three minutes on shrubs, and fifteen to twenty minutes on trees.

**Fertilizing:** Plants should be fertilized on a regular basis. Contact a lawn-care specialist for proper maintenance guidelines.

**Trimming:** Hedges and plants should be trimmed monthly to encourage growth and conformity to the intended design.

## **D. Sprinkler Irrigation System**

Many homes have an automatic sprinkler system installed, and this is by far the most efficient method for watering your lawn.

There are two systems in use:

1. an individual irrigation system for each home controlled by an individual time clock
2. a community irrigation system. This system is regulated by community time clocks generally controlled and maintained by a Home-owner Association. It draws water from a lake or well within the community.

**NOTE:** *If your irrigation system fails to operate after rain, your home may have a rain sensor installed. The sensor turns off the system for a period of time, depending on the rainfall.*

## **Maintenance Guidelines: Sprinkler Irrigation System**

Most sprinkler systems are controlled by an automatic time clock. Refer to the instructions on setting the time clock and watering times on the inside cover of the timer.

Keep grass and shrubs trimmed around the sprinkler heads.

Occasionally, the sprinkler heads will clog with sediment build-up and will need to be removed and cleaned. Refer to your manufacturer's instructions on how to complete this task.

Depending on soil conditions, type of grass and time of year, your sprinkler system can be adjusted to run every day, every other day or certain days of the week. Also be aware that local water restrictions can prevent you from watering on certain days or times of the day. A good time to water your lawn with a sprinkler system is between 2:00 am and 9:00 am.

Your lawn is divided into several "zones" depending on the size of the lawn. To test the system, turn the sprinklers on manually. Each zone should be checked for proper coverage and for properly operating sprinkler heads. If something is leaking, call a sprinkler contractor immediately.

## **Mirrors & Shower Enclosures**

### **A. Mirrors**

Clean bathroom mirrors and shower enclosures with an ammonia-free spray glass cleaner and a soft cloth, wiping several times to remove all glass cleaner residue. Most mirror failures are at the edges where "spillover" solutions attach the backing. By applying cleaner to the cloth rather than the mirror, this can be prevented.

Do not use abrasive cleaners which will permanently scratch and mar mirror or glass surfaces. Do not expose mirror products to salt air for extended periods of time. Humidity, heat and dampness can cause permanent damage, so provide adequate ventilation in rooms with mirrors.

Some mirrors will have some minor imperfections. This is perfectly normal. All scratches and other defects in mirrors and glass tub/shower enclosures must be reported to your builder at time of the orientation/walk through and not after closing.

## **Common acceptable defects include:**

1. Slight hairline face and back scratches
2. Slight pinhead bubbles or seeds
3. Slight rubs
4. Slight discoloration
5. Slight dings or bruises

## **B. Shower Enclosures**

Shower enclosures create extreme amounts of moisture, so frequent checking of joint areas is recommended. Check caulking periodically to ensure against leaking. The homeowner is responsible for recaulking as needed. The use of clear silicone is not recommended as it yellows with age.

## **Painting & Caulking**

The interior walls of new homes are generally painted with a latex paint. We strongly recommend that touch-up paint be used instead of washing the walls. The exterior walls of your home have been painted with a quality exterior paint.

### **A. Interior and Exterior Paint**

**Painting Note:** The builder cannot guarantee that painting repairs requiring new material will match the color of the existing material. Paint repairs may show slight variations in color because of weathering, aging or pigment variations in different paint manufacturing runs. Color and texture variations are normal. Fading is also normal, and the degree is dependent on climate conditions.

**Touch-up:** Paint touch-up is visible under certain lighting conditions.

When doing paint touch-ups, use a small brush, applying paint only to the damaged spot. Touch-up may not match the surrounding area exactly, even if the same paint mix is used. When repainting a room, prepare the wall surfaces by cleaning with a mild soap and water mixture or a reliable cleaning product.

Check your home's exterior painted and stained surfaces annually. Repaint before much chipping or wearing away of the original finish occurs; this will save the cost of extensive surface preparation.

Plan on refinishing the exterior surface of your home every two or three years or as often as your paint manufacturer suggests for your area and climate.

Climatic conditions control the chemical structure of the paint used on the exterior. Over time, the finish will fade and dull a bit.

When you paint the exterior of your home, begin by resetting popped nails and removing blistered or peeling portions of paint with a wire brush or putty knife. Sand, spot with primer and then paint the entire area. Use a quality exterior paint formulated for local climate conditions. Avoid having sprinklers spray water on the exterior walls of your home. This will cause blistering, peeling, splintering and other damage to the home.

**Cracking:** As it ages, exterior wood trim will develop minor cracks and raised grain. Much of this will occur during the first year. Raised grain permits moisture to get under the paint and can result in peeling. This is not a defect in materials or workmanship. Paint maintenance of wood trim is your responsibility.

**Cleaning Exterior Painted Surfaces:** Lack of or little sunlight, moisture and damp weather conditions may cause the formation of mildew or fungus on the exterior. Mildew or fungus can be removed by carefully washing the affected area with a water-diluted household bleach. The builder is not responsible for mildew or fungus build-up. See Exterior Wall Finishes for further information.

**Cleaning Flat-Latex Painted Surfaces:** In many homes an off-white, lead-free latex paint is applied to the interior walls of the home. This is not a washable paint and will smudge if cleaned. We do not recommend washing these surfaces, but instead suggest using touch-up paint to cover paint scuffs and marks.

**Cleaning Semi-Gloss Painted Surfaces:** An off-white, lead free semi-gloss paint is applied to interior wood trim and doors. These surfaces may be cleaned with a sponge and lukewarm water. The less moisture on the sponge, the better. Wipe quickly with a gentle pressure from top to bottom without allowing the solution to run down the door or trim.

If the water does not work, try the same procedure using a small amount of mild detergent mixed with water. Once complete, lightly rinse the washed area with plain water and allow to dry.

## B. Caulking

Caulking is a building joint sealant used where two dissimilar materials are joined. In time, caulking hardens, shrinks and cracks even when properly installed. Caulking should be renewed prior to any repainting.

**NOTE:** *Caulking is a homeowner's responsibility. Caulking around windows and doors should be checked and recaulked at least once a year.*

Exterior caulk will eventually shrink, separate and deteriorate, causing it to pull away from surfaces and create areas for water and air to infiltrate. This should be monitored constantly because moisture can work its way behind wood trim or siding and cause rotting. Pay particular attention to the caulking at doors and windows; if separation of the caulking occurs, it can result in leaks. When recaulking on the exterior, use a product that paint will adhere to.

### **Maintenance Guidelines: Caulking**

Changes in temperature and humidity cause building materials to expand and contract, sometimes at different rates. This movement causes the materials to separate. Separation can lead to small cracks in drywall and in paint, especially where moldings meet drywall, at mitered corners and where tile grout meets tub or sink. While this can seem alarming, it is normal.

Shrinkage of the wood members of your home is inevitable, and usually happens during the first year, it may continue beyond that time. In most cases caulk and paint can conceal any noticeable effects from shrinkage.

**Acrylic Latex with Silicone Caulk:** All-purpose caulk that is mildew-resistant, flexible and paintable.

**Latex Caulk:** Appropriate for areas that requires painting, such as along the stair stringer or where wood trim meets the wall.

**Silicone Caulk:** Will not accept paint; it works best where water is present, for example, where tub meets tile, or a sink meets a countertop.

**NOTE:** *Consult a sales professional at your local hardware store or home improvement center if you are unsure about which caulk to use for a specific job.*

---

## Solutions to Common Painting Problems

---

<b>PROBLEM</b>	<b>LIKELY CAUSE</b>	<b>SOLUTION</b>
Exterior paint peeling.	Surface not cleaned	Scrape, sand, prime and repaint.
Blisters in paint.	Moisture/solvents under paint surface.	Scrape, fill resulting depression, Sand, prime and repaint.
Wrinkling, runs and/or drips.	Poor adhesion caused by water or solvent trapped under paint	Sand smooth and repaint.
Interior and/or exterior caulking cracks or shrinks.	Paint applied too thick	Remove old caulking only if unsightly. Caulk open gaps.
Paint peeling off masonry.	Normal drying, settlement, expansion and contraction	Scrape peeling paint. Repaint with latex paint
Efflorescence or peeling on foundation.	Surface not cleaned. Moisture/solvents under paint surface.	Scrape, apply alkali neutralizer, repaint.
Bleeding wood knots	Alkali compounds on foundation.	Sand, apply stain killer, repaint.
Mildew on painted surfaces.	Wood resin seeping out. Fungus from moisture and little sunlight.	Carefully wash with water-diluted chlorine bleach.

## Plumbing System

A licensed plumbing contractor installed all plumbing pipes and systems in your new home. These have been tested and inspected.

In most cases, minimum Homeowner's Maintenance is all that the plumbing system requires. Attending to small problems as they occur keeps them from becoming larger, more costly problems later.

### A. Water Lines

Your home is served by a well or a city water supply. The pipes that carry water into the home are designed to resist rust and corrosion.

### **Maintenance Guidelines: Plumbing System**

**Noisy Pipes:** Noisy water pipes should be corrected immediately since the resulting vibrations can damage plumbing line fittings and cause them to leak. There is one exception: Exterior hose faucets often produce a high-pitched noise caused by an attached vacuum breaker or back-flow preventer. This noise is normal and not cause for concern.

Noisy pipe problems can be identified and corrected as follows:

1. The water heater temperature may be set too high, producing steam in the pipes. To resolve, gradually reduce the water heater temperature setting until the steam is reduced.
2. Abruptly turning off a faucet in areas with high water pressure can produce a pounding or knocking sound. To resolve, slightly close the main shut-off.
3. Air can get into the pipes; to resolve, open all interior and exterior faucets and run for a few minutes, allowing all air to pass through the system.

**Freezing Pipes:** Provided the home is heated at a normal level, pipes should not freeze. Set heat at 65° F if you are away during winter months. Keep garage doors closed to protect plumbing lines that run through this area.

### B. Main Shut-off Valve

This is the center of the plumbing system, the point at which the main water line comes into the home. If a major plumbing problem occurs, turn off the main shut-off valve to prevent flooding.

It is a good idea to show every family member where the shut-off valve is, explain how to close it in case of an emergency and mark it with an easy-to-locate identification tag.

### C. Water Intake Valves

Most plumbing fixtures in the home have a water intake valve to individually shut off the water to that fixture for minor repairs and emergencies. Show family members how to operate them and where they are located on sinks, bathtubs, showers, toilets, water heater, washing machine and laundry tub. Toilet valves are behind the toilet and sink valves are under the sink.

### D. Drain Traps

Every plumbing fixture in the home is equipped with a drain trap, an S-shaped pipe that holds water and acts as a barrier to keep airborne bacteria and sewer gas odors from coming back into the home. If a sink or bathtub fixture is not used frequently, turn it on periodically to replace evaporating water and to keep the water trap barrier intact.

**Guidelines:** Drain traps can be cleaned by putting three tablespoons of ordinary dishwashing detergent into the drain. Add a little hot water, let stand for 15 minutes, then flush with hot water. Use a rubber plunger to unclog a blocked toilet.

**CAUTION:** Do not pour grease into drains or toilets or use caustic cleansers to open plugged drains. Do not use a plunger with any drain cleaning chemical. When using a chemical drain cleaner, carefully follow the manufacturer's safety precautions and product directions.

### E. Sanitary Sewer Lines

In the final stages of preparing your home for move in, the plumber tested and flushed the sewer lines to ensure they were clear and working properly.

## **Maintenance Guidelines: Sanitary Sewer Lines**

Do not put hair, grease, lint, garbage, heavy tissue, disposable diapers or sanitary materials into the sewer system.

When operating the garbage disposal, always use a generous amount of cold water to keep the sink drain clear and the disposal motor cool.

Tree roots causing breaks in sewer lines or main lines are a homeowner's responsibility.

## **F. Septic Tanks**

The septic tank is primarily a holding tank, generally made of concrete or fiberglass, for all the waste coming from your home by way of the kitchen sink, bathrooms, laundry tubs and washing machines.

Your builder will tell you if your home is part of the municipal sewer system or if it uses a septic system for household waste. If you do have a septic tank, your builder should have shown you the location of the tank and its drainage field during the orientation to your new home. Thereafter, check with your local health department for cleaning and disposal recommendations.

## **Maintenance Guidelines: Septic Tanks**

Homeowners are responsible for the proper maintenance of the septic tank. For best results, inspect your septic tank and the drainage field area at least once a year.

The frequency of septic tank cleanings varies depending on the tank size, daily sewage intake and the number of people it serves. Generally, septic tanks should be cleaned every two years.

Cleaning a septic tank requires special knowledge and tools. This is not recommended as a "do-it-yourself" project. Periodic pumping of the septic tank between cleanings is considered a homeowner responsibility.

As warm weather causes bacterial action to increase, septic tanks should be cleaned in the spring. The waste material should be disposed of in a manner approved by your local health department, and only a licensed septic tank contractor should be used.

The need for pumping is considered normal and not a deficiency. Ask your professional septic tank contractor to recommend a pumping timetable for your usage. Failure to do so might cause problems.

Do not allow petroleum products, paint thinners, solvents, harsh chemicals, cleaning fluids, dyes, excessive amounts of bleach, cigarettes, dental floss, kitty litter, sanitary napkins or plastics to enter the septic system.

Never allow grease, cooking fats or gristle to go down the drain or through the garbage disposal. Save the fat in a jar or can and put it in the garbage can outside your home. Avoid using drain cleaners and high-foaming detergents if you have a septic system. These substances will clean away the natural bacteria that the system needs. Use non-phosphate cleaners and biodegradable laundry soaps.

If you have a garbage disposal, do not grind large amounts of vegetable and fruit matter as it may create the need for more frequent cleanings. Avoid putting coffee grinds in the disposal. Do not connect roof drains or allow backwash from a water softener to enter the septic tank system. Do not allow a sump pump to discharge into the septic tank system.

Vehicles should not be driven or parked over septic tanks or drainage fields. Trees and shrubbery should not be planted in the drain field.

## **Warning signs that something is wrong:**

1. You notice that the wastewater backs up or the toilet bowl does not drain properly when you flush a toilet.
2. Wastewater backs up in any other drain.
3. "Gurgling" sound in the plumbing.
4. Grass in the yard grows faster and is greener in one area, especially along the path that leads to the septic tank.
5. Ground is mushy underfoot in one area of the yard.
6. Obnoxious odors inside or outside the home, especially around drains.
7. Low spots begin to appear in the yard, whether any of the above symptoms have occurred.

## Solutions to Common Plumbing System Problems

<b>PROBLEM</b>	<b>LIKELY CAUSE</b>	<b>SOLUTION</b>
No hot water from electric water heater.	Tripped circuit breaker.	Check and reset circuit breaker.
No hot water from electric water heater.	Temperature setting too low	Adjust temperature setting.
Hot water recovery is low.	Burned out heating element	Replace heating element. Check circuit breaker.
Toilet runs constantly.	Water level in tank is too high.	Adjust float arm stem in toilet water tank downward.
Toilet makes loud noise when flushed.	Ball cock in water tank is not working properly.	Replace ball cock in toilet water tank.
Toilet makes dripping or gurgling noise.	Warped or worn out flapper valve.	Replace flapper valve.
Toilet backing up or overflowing.	Obstruction in line.	Turn toilet intake valve off and plunge toilet
Hose sprayer in kitchen sink drips.	Dirty or defective.	Clean or replace.
Slow draining sink or bathtub.	Blockage such as hair at drain.	Remove hair or blockage.
Water flow from faucet is reduced.	Aerator at tip of faucet is clogged.	Unscrew aerator screen and rinse.
Water splatters out of faucet.	Air in water supply line.	Open all faucets in home for five minutes.
Water leaking from under sink.	Loose plumbing fitting.	Hand tighten couplings on drain pipes.
Water dripping from shutoff valves.	Loose packing nut.	Open valve all the way, then gently tighten nut.
Garbage disposal clogged.	Obstruction in line.	Use disposal wrench on bottom of disposal.
Garbage disposal will not operate.	Tripped reset button.	Check reset button on bottom of disposal.

## Plumbing Fixtures

The plumbing fixtures in most homes include the water heater, bathtubs, showers, toilets and sinks. **NOTE:** *As equipment technology changes frequently, the manufacturer's service manuals will supersede all recommendations and procedures contained in this manual.*

### A. Water Heater

The electric water heater is equipped with an automatic temperature and pressure relief valve, a safety feature that opens and releases excessive pressure or heat build-up. Should this occur, water will flow from the tank until both temperature and pressure are reduced to safe levels.

### **Maintenance Guidelines: Plumbing**

#### **Fixtures**

**Hot Water Temperature:** Water temperature is set at 120° F by the manufacturer. While low temperature settings reduce utility costs, bear in mind that dishwashers do not operate properly with settings below 120° F.

**NOTE:** *Do not store combustible items, oily rags, clothing, brooms or dust mops near the water heater as this presents a potential fire hazard. Do not use the top of the water heater as a storage shelf.*

**Scale:** Small amounts of scale deposits will collect and settle on the bottom of the water tank. Remove this residue annually by draining the tank. Shut off the power first, using the appropriate circuit breaker in the electrical power box. Attach a garden hose to the valve and run it outside. Then open the valve at the bottom of the water heater, allowing residue to drain out until the water runs clear. If you live in a hard water region, a water softener will reduce the need for more frequent draining.

Do not completely drain an electric water tank without first shutting off the water heater circuit breaker. Do not turn circuit breaker on until the tank is full of water.

**Element Cleaning or Replacing:** The heating elements in the water heater will require periodic cleaning. The frequency is determined in part by the quality of the water in your area. Again, refer to the manufacturer's literature for step-by-step instructions and drawings, or contact an authorized service company.

**No Hot Water:** If you discover you have no hot water, check the breaker, the temperature setting and the water supply valve before calling for service. Refer to the manufacturer's literature for locations of these items and other troubleshooting information.

**Pressure Relief Valve:** At least once each year, manually operate the pressure relief valve. Stay clear of the discharge line to avoid injury. See manufacturer's literature for diagrams and detailed instructions.

**NOTE:** *If the pilot does not light right away, close the shut-off valve and call the gas company.*

### B. Fixtures

Kitchen and bathroom sinks, toilets and bathtubs are made with cultured marble, plastic, fiberglass, stainless steel, or steel finished with porcelain.

### **Maintenance Guidelines: Fixtures**

To clean, use a non-abrasive spray cleanser and sponge. Dropping heavy objects onto porcelain or fiberglass can chip or crack the surface and may produce permanent staining. Do not leave steel wool pads on sink surfaces, as they will rust and stain the surface.

Be aware that continuous-action toilet bowl cleansers, placed in the toilet water tank, will prematurely wear out the rubber tank flapper and may discolor the bowl. Follow the manufacturer's recommendations for cleaning and maintenance.

### C. Kitchen Sinks/Stainless Steel and Cast Iron

For routine cleaning, use a non-abrasive household cleanser with warm water and a sponge. Do not scrape the surface with utensils, pots or pans. Do not leave leftovers in sink or strainer, particularly tea bags and coffee grounds, which contain harmful acids. Regular washing soap — not baking soda — should be added to the drain to keep it grease and soap-free.

Do not clean stainless steel sinks with steel wool or metal brushes, and do not leave rubber mats in the sink since they trap water and produce surface discoloration. To restore luster to stainless steel, apply a small amount of mineral oil with a soft cloth, then wipe dry.

## D. Garbage Disposal

Always use cold water when disposal is working. Corn cobs and husks, bones, celery or any other food that shreds should not be put into the disposal. If the machine becomes jammed, use the wrench to free the mechanism and try again. The disposal will rust if not used regularly. If you are going to be away for an extended period of time, a teaspoon of oil will help prevent the mechanism from freezing.

## E. Bathroom Sinks

Sink surfaces can be easily chipped and stained, so treat them accordingly. Prevent hair accumulation clogs by periodically removing the stopper for cleaning or purchase a rubber hair collector. Avoid setting lit cigarettes on the edge of the sink, as they will burn and permanently damage the surface.

## F. Toilets

A water-saving regulation went into effect in 1993. It prohibits the manufacture of toilets that use more than 1.6 gallons of water per flush. In the search for a balance among comfort, convenience and sensible use of natural resources, the government conducted several studies. The 1.6-gallon toilet turned out to be the size that consistently saves water.

**NOTE:** *Your new toilets are different if you moved from a residence that was built prior to 1993. Toilets prior to 1993 used three gallons to flush and were not as inclined to stop up.*

As a result of implementing this standard, flushing twice is occasionally necessary to completely empty the toilet bowl. Even though you flush twice on occasion, rest assured that overall, you are saving water and complying with the law.

**Running Toilets:** To stop running water in the toilet, check the shut-off float in the tank. You will most likely find it has lifted too high in the tank, preventing the valve from shutting off completely. In this case, gently bend the float rod down until it stops the water at the correct level. The float should be free and not rub the side of the tank or any other parts. Also check the chain on the flush handle. If it is too tight, it will prevent the rubber stopper at the bottom of the tank from sealing, resulting in running water.

## G. Bathtubs, Showers and Tub Shower Combinations

**Cleaning:** Clean porcelain-on-steel bathtubs, cultured marble tubs and sinks, fiberglass showers, tub/shower combinations and shower stall floors with warm water and a non-abrasive cleanser. Clean glass shower doors with a commercial glass cleaner. Check bathtub stoppers and shower floor drain grates for hair accumulation. Do not use ammonia-based cleaners. Gel-Gloss is recommended for polishing cultured marble.

**DO NOT STEP INTO A BATHTUB OR TUB/SHOWER WITH SHOES ON. GRITTY PARTICLES ADHERE TO YOUR SHOE SOLES AND WILL SCRATCH THE FINISH.**

**Recaulking of Tubs and Showers:** Over time, cracks and separations between tub or shower stall and wall surfaces or bathroom floors will appear. Maintaining these areas is critical since excessive moisture can severely damage underlying materials.

It will be necessary to reapply a tub and tile caulk when the previous caulking has dried out or eroded. To recaulk the area, use a tub and tile caulk available in local hardware stores. Do not use a clear silicone caulk, as it yellows with age. Begin by removing the old caulk and cleaning the area. Once the area is dry, apply fresh caulking to fill the vacant space, then smooth out the finish with a wet finger.

## H. Whirlpool Tub

**CAUTION:** *Never run the pump motor without at least two inches of water above the jets. Running the pump with improper water levels will damage it. Always turn the pump off during draining. Do not add bath oils, bubble soap or any other liquid to the water.*

### **Maintenance Guidelines: Whirlpool Tub**

1. Check for leaks periodically by looking around the base of the tub.

2. Every two to three months, fill the tub with hot water and add a small amount of liquid dishwasher non-foaming detergent. Run the pump for 10 minutes. This will clean the pipes and the pump's internal parts.

## I. Interior Faucets

interior faucets are either single-lever faucets or washer faucets.

### **Maintenance Guidelines: Interior Faucets**

**Single-Lever Faucets:** The single-lever kitchen and bath faucet are low-maintenance, washerless faucets. Should the cartridge ever need to be replaced, turn off the water supply under the sink, remove the handle assembly, and pull the cartridge out. Take the cartridge to a local plumbing supplier and match accordingly, being sure to follow installation instructions.

**Polished Brass Fixtures:** Polished brass in humid regions is sure to pit and tarnish. Besides the climate, there may be other catalysts that cause this reaction to occur. Cleaning agents, standing water, shampoos, toothpastes and personal hygiene products are among items that may heighten the tarnishing and pitting process. Any cleaning agent that contains harsh chemicals will most certainly wear through the protective coating applied to brass. The manufacturers of polished brass recommend the use of plain water and polishing with a soft cloth.

**Chrome Faucets:** Chrome Faucets should be cleaned with a soft damp cloth and a commercially accepted cleaner. Dry the faucet with a soft cloth. Never use an abrasive or ammonia-based cleaner.

**Washer Faucets:** A washer faucet has a shut-off feature that requires light closing pressure to stop the flow of water. Do not apply too much pressure since washers can be damaged.

**Faucet Aerators:** Screened aerators screw into the spout of a faucet to add air to the flowing water which reduces splashing. Aerators are easy to remove for periodic cleaning. This should be done every three to four months.

**Washer Replacement:** Dripping faucets can dramatically increase water bills and represent the loss of a valuable natural resource. Over time, all washers will wear out and must be replaced. Neglecting to change washers may cause damage to the valve seat or to the entire faucet. Many homeowners prefer to do this simple replacement procedure themselves:

1. Turn off the water supply intake valve located under the sink.

2. Using a wide-jaw wrench, remove the hexagonal cap from the top of the faucet assembly. This may take just a turn or two.

3. Remove the inside part, turn it upside down and you will see a fiber washer held by a screw through its center. This is the source of the leak. The screw can easily be removed, but the washer itself may take a little prying to remove.

4. Match the new washer to the worn out washer and replace it. Re-use the same screw if it is in good condition. Then, reassemble the faucet.

## J. Exterior Hose Bibs

Exterior faucets are called hose bibs. To replace washers on standard exterior faucets, follow the same procedure for washer replacement as stated above.

Check for leaks and replace washers as required since a leaking exterior faucet can cause water damage.

**Water Back-flow Prevention:** Most new homes have a vacuum breaker installed on the exterior hose faucet. This device prevents back-flow and stops potentially contaminated water from flowing back into the home water supply system via the garden hose. These devices are a plumbing code requirement and may not be removed.

With a vacuum breaker installed, it is normal to hear a humming or vibrating noise throughout the home when the exterior faucet is on. This is caused by the washers built into the back-flow preventer and is not a reason for concern.

## Roofing, Gutters, Downspouts

The roof of most homes is constructed with a two-ply roof system which consists of roofing felt and plywood or sheathing. Tile or shingles are installed following manufacturer's guidelines and product specifications.

*For more information on roof sheathing and insulation, see section on Framing and Carpentry.*

### A. Tile Roofs

Tile comes in many different forms, including "color through" tile, painted tile, glazing tile, flat and S-shaped tile. These tiles are for decorative covering only.

**CAUTION:** *Do not walk on your roof, as this can cause the tiles to crack and break, and possibly to move. The builder is not responsible for replacing broken tiles or loss of tiles due to high winds. Use caution when placing holiday decorations on or near the roof tile.*

### B. Shingle Roofs

Shingle roofs come in many different colors and styles. Shingle roofs provide water protection to the roof underlayment. As above, the builder is not responsible for damage to shingles caused by the homeowner.

### C. Metal Roofs

Metal roofs come in a variety of colors and styles. They are light weight, extremely fire resistant, durable and are energy efficient by reflecting the sun's energy.

**Aluminum Roof Caution:** *Do not walk on the roof. It is not designed to hold your weight without some kind of horizontal bridging.*

### D. Flashing

Roof flashings are sheet-metal trims used around roof openings, on vent stacks, roof vents and valleys. Their purpose is to channel water away from the house.

### E. Gutters and Downspouts

Where applicable and installed, gutters channel water run-off from the roof to downspouts that guide the water to ground-level drainage areas.

## **Maintenance Guidelines: Roofing, Gutters, Downspouts**

Gutters and downspouts should be inspected and cleaned regularly. Clear the gutter of accumulated debris such as leaves, twigs, branches, balls and other objects.

Gutters need to slope slightly downward to channel water to the downspout. Splash blocks can be properly positioned at the bottom of the downspout to direct water away from the foundation. Finally, the soil grade must slope away from the home. The best advice is to keep the gutters free of debris.

Splash blocks can be properly positioned at the bottom of the downspout to direct water away from the foundation. The soil grade must be sloped away from the home. Gutters and downspouts should not leak but may overflow during heavy rain.

### F. Vents

Vents should remain unobstructed year-round. If your home has soffit vents and/or ridge vents, they should be cleared of debris. Ridge vents should be checked periodically to ensure they are secure and have not come loose in high winds. Also, check that these vents have not been stepped on and deformed. Excessive heat build-up in the attic is usually caused by blocked air vents. This condition can be resolved by clearing all obstructions away from the vents to allow proper heat release.

There are a variety of attic vents that could be used in your home. The different types can be soffit vents (located in the eaves of your roof), ridge vents (found at the peak of your roof) and attic vents (sometimes known as whirly birds, turtlebacks and mushrooms). Familiarize yourself with all the different vents on your home.

## Screen Enclosures

The screen enclosure that you have selected for your home (where applicable), is likely an aluminum, rust-free structure with the architecturally controlled colored nylon screen attached.

## **Maintenance Guidelines: Screen Enclosures**

Periodic pressure washing by a professional is recommended. The use of diluted vinegar and water will retard mildew growth on the frame.

**CAUTION:** Do not use chlorine or acid on the aluminum as a chemical reaction will occur.

Screens are designed to pop out under strong wind conditions. Therefore, there is no guarantee on the screens to stay rolled in. Tears and cuts in the screening after closing are a homeowner's responsibility

## Shelving

Unless wood shelves are installed, shelves are fabricated of heavy gauge welded steel rod covered with a protective plastic coating. The shelving will support a static load of 75 pounds per three linear feet, evenly distributed.

## Shutters (Hurricane)

If your home is equipped with removable panel hurricane shutters, it is a good idea to practice installing the panels once a year to ensure that you and your family are familiar with the procedure. The builder estimates that shutter installation should take two people approximately four hours for a one-story home and eight hours for a two-story home. You should clearly mark the panels and store them carefully in your garage. The panels may be made of galvalum (steel with a galvanized aluminum surface), which should not rust unless the panels are damaged and exposed to moisture. Do not lay flat on the garage floor, as the moisture from the concrete will rust the panels.

If your home has accordion shutters, you should check all tracks to make sure they are free from debris and lubricate as needed to ensure smooth operation prior to the start of the hurricane season (June through November).

**CAUTION:** Use work gloves when handling the panels and only use ladders that meet OSHA standards. Safety shoes should be worn. If the homeowner wishes to purchase shutters, consult a licensed shutter company for proper permitting, etc.

### **Maintenance Guidelines: Hurricane Storm Panel**

1. Your home should have a numbered drawing of each opening.
2. Each storm panel should be numbered to match each opening.

3. For easy installation, all storm panels should first be set outside each opening with matching numbers.

4. Always wear a pair of work gloves to protect hands and fingers.

5. Vertically installed storm panels should start from left to right.

6. Horizontally installed storm panels should start from the bottom up.

7. A hardware package containing nuts and bolts necessary to secure the storm panels to your home, along with a screwdriver, should be stored in a handy and safe place along with numbered openings of your home.

8. We suggest storing a ladder with the storm panels to safely reach higher openings.

9. After your storm panels are installed and secured to your residence:

- Check canned food supply
- Check water supply
- Check batteries and flashlight
- Check evacuation route, if necessary
- Stay tuned to local news station for updated information

10. Taking down and restoring: Do not lay flat on the garage floor as the moisture from the concrete may rust the panels.

## Stairs

### **Maintenance Guidelines: Stairs**

No known method of installation prevents all vibration or squeaks in a wood staircase. A shrinkage crack may develop where the stairs meet the wall. If this occurs, apply a thin bead of latex and, when dry, touch up with paint.

## Swimming Pool

Swimming pools are sold as options by most builders. The pool requires regular maintenance. Read the following guidelines and follow the instructions your pool contractor gives you to avoid costly repairs.

Hairline cracks in the pool decking are common due to weather conditions and settlement. Hairline cracks are considered normal and require no repair.

### **Maintenance Guidelines: Swimming Pool**

1. The pool finish takes from four to six weeks to cure. During this period, it is important to brush the walls and floors at least three times per week to eliminate permanent stains caused by settling dirt or minerals.
2. Water should be kept about halfway up on the skimmer opening. Evaporation loss will vary from 1/2 inch to 1 1/2 inches per week depending on weather conditions.
3. Test the pool water weekly, preferably at the same time of the day, and after the pump has been running at least five hours. Samples should be taken from below elbow depth (18 inches). Consult with the contractor for proper chemical balance.
4. When brushing the pool, open the main drain and close the skimmer, then brush walls, steps and swim outs first. When brushing the floor, work from the shallow end toward the deep end and the drain.
5. Pool filters should be cleaned once a week. Remove the cartridge filter, hose it down, then clean the hair/lint trap basket. The pool pump must be in the "off" position. The pool pump has been installed with a timer that should be set to run 8 to 10 hours per day in the summer and 6 hours in the winter.

**CAUTION:** *Fertilizer will cause permanent rust stains on the pool marcite.*

## Windows/Screens

Typically, the windows in your new home are single-pane glass and are framed in aluminum. The manufacturer has sealed all the glass to the frame and the frame has been attached to your home and caulked.

**NOTE:** *It is the homeowner's responsibility to check and re-caulk all exterior frames. All window scratches or imperfections must be reported to your builder at time of orientation/walkthrough, not after closing.*

### **Maintenance Guidelines: Windows/Screens**

**Cleaning Window Glass:** Clean windows with a commercial glass cleaner or a cup of vinegar mixed with a gallon of warm water. Apply with a sponge or lint-free cloth, then dry and polish with paper towels. A rubber squeegee passed over glass surfaces will speed the drying and eliminate streaking.

**Aluminum Windows:** Abrupt changes in weather may cause aluminum windows to bind or stick. Should this occur, apply silicone spray to the window sash tracks. Aluminum window frames have a baked enamel finish and may be cleaned with a mild detergent solution. Be aware that aluminum window frames will weather due to exposure to the outside elements.

**Window Condensation:** The appearance of moisture that occurs when warm moist air comes in contact with a colder surface is called condensation. While moisture may appear on the windows, this does not indicate a window problem. The most common cause is humid air outside the home hitting the cold surface of the window glass. Wipe up condensation as quickly as possible in order to avoid staining the drywall, window sill or caulking.

**Weep Holes:** In heavy rains, water may collect in the bottom channel of window frames. Weep holes are provided to allow excess water to escape to the outside. Keep the bottom window channels and weep holes free of dirt and debris for proper operation.

**Window Screens:** Their sole purpose is to help prevent insects from coming inside when the windows are open. Window screens may be washed and rinsed using a mild household detergent.

**Storing Screens:** Many homeowners remove and store screens for the winter to allow more light into the home. To make re-installation more convenient, label each screen as you remove it. Use caution; screens perforate easily and the frames bend if they are not handled with care.

**CAUTION:** *Window screens will not prevent children from falling through open windows to the ground below. The screen is not a barrier, and the fastening system for the screen will not support any weight beyond the screen itself. Never allow children near an opened screened window, or place any weight on or push against a window screen. Do not place furniture near windows so that children have easy access.*

## Solutions to Common Window Problem

<b>PROBLEM</b>	<b>LIKELY CAUSE</b>	<b>SOLUTION</b>
Aluminum window binds or is difficult to open.	Broken window balance.	Replace balancer.
Aluminum window binds or is difficult to open.	Paint or dirt on jambs.	Clean jamb and spray with silicone.
Aluminum window will not stay open.	Weak window balancer.	Replace balancer or adjust tension rod.
Aluminum window will not slide up or down.	Tension rod jammed.	Adjust balance or tension rod.
Aluminum window sash comes out when fully opened.	Tension rod clips on side jambs left in open position.	Position clips in closed position before opening.
Aluminum window will not lock properly.	Debris in track or window not aligned properly.	Clean track or check alignment at middle when closing.
Condensation on inside surface of window.	High humidity inside home.	Reduce humidity with exhaust fans and dehumidifier.
Cracked glass.	Normal settlement.	Replace cracked glass.

# Systems & Appliances Catalog

## Appliances

**MANUFACTURER**

**MODEL NUMBER**

**SERIAL NUMBER**

**Built-In  
Microwave**

**Clothes Dryer**

**Clothes Washer**

**Cooktop**

**Garbage Disposal**

**Dishwasher**

**Wall Oven**

**Range**

**Refrigerator**

**Trash Compactor**

**Water Heater**

**Freezer**

# Systems & Appliances Catalog

	<b>Systems</b>		
	<b>MANUFACTURER</b>	<b>MODEL NUMBER</b>	<b>SERIAL NUMBER</b>
<b>Air Conditioning</b>			
<b>Heating System</b>			
<b>Intercom System</b>			
<b>Septic System</b>			
<b>Central Vacuum System</b>			



# 4

# Glossary of Construction Terms

**AERATOR**

A small, removable extension at the tip of a sink faucet that mixes streaming water with air to reduce splashing and conserve water.

**AIR HANDLER**

A unit that is part of the air conditioning system located in either the garage or interior closet that circulates cool air from the condenser throughout the house.

**AIR HAMMER**

A banging noise in plumbing pipes caused by air infiltration.

**AIRWAY**

The space between roof installation and roof boards which allows for movement of air.

**ANCHOR BOLTS**

Bolts that secure a wooden sill plate to a concrete or masonry floor or wall.

**ASPHALT**

A residue from evaporated petroleum, insoluble in water but soluble in gasoline. Melts when heated.

**ATTIC VENTILATORS**

Screened openings provided to ventilate an attic space.

**BALL COCK**

A device in a flush toilet consisting of a valve connected by a lever to a floating ball. The valve closes when the ball is raised and opens when it is lowered.

**BASEBOARD**

A decorative and protective wood molding positioned where the wall meets the floor.

**BASE MOLDING**

Molding used to trim the upper edge of interior baseboards.

**BEAM**

A structural member transversely supporting a load.

**BEARING WALL**

A wall that supports any vertical load in addition to its own weight. Often used on walls as temporary bracing until framing has been completed.

**BRICK VENEER**

A facing of brick laid against and fastened to sheathing of a frame or tile wall.

**CASING**

Molding of various widths and thicknesses used to trim door and window openings at the jambs.

**CAULK**

A building joint sealant used where two dissimilar materials are joined. In time, caulk hardens and cracks and should be renewed prior to any painting.

**CIRCUIT BREAKER**

A switching device, located in the main electrical panel that opens and closes electrical circuits and automatically shuts off electricity to a circuit should it become overloaded. Once the electrical load is reduced, the breaker switch can be turned back on to resume normal service.

**CONCRETE DUSTING**

A fine dust that accumulates on finished concrete surfaces.

**CONDENSER**

An exterior unit that is part of the air conditioning system which expels heat onto the outside air.

**CONDUIT, ELECTRICAL**

A pipe, usually metal, in which insulated wire is installed.

**CORNER BEAD**

An angled metal edging used to protect and form an edge where drywall panels meet at outside edges.

**DAMPER**

A device in a fireplace that controls the air draft allowed into the fire.

**DELAMINATION**

The separation of the top piles or laminate from the base to which they are attached. In vanity and kitchen countertops, the warping or detachment of laminate material from the wood substrate.

**DETHATCHING**

The loosening and/or removal of matted grass and leaves from existing lawns, which allows the grass to breathe and therefore promotes healthy growth.

**DOWNSPOUT**

A pipe, usually metal, for carrying water from roof gutters.

**DRYWALL**

Also known as gypsum board or sheetrock, these large sheets are attached to the wall studs and ceiling framing to construct the walls and ceiling of the home.

**EAVES**

The margin or lower part of a roof projection over a wall.

**EFFLORESCENCE**

A white powdery substance that can form on new block, brick or stucco finishes. It is composed of water-soluble salts that are present in masonry materials and that rise to the surface via water vapor.

**FACE FRAME**

The front of kitchen and bathroom cabinets, to which the hinged doors attach.

**FACE NAILING**

Nailing through a finished, exposed surface so that the flat top of the nail head is still visible after nailing.

**FACIA OR FASCIA**

The exterior horizontal trim around rafters. Also positioned directly behind gutters and over gable trim boards.

**FILLER BOARD**

Cabinet-grade wood used to fill gaps that occur between cabinets and wall openings.

**FILLERS**

A wood putty used in preparation for painting to fill holes or cracks in wood.

**FLASHING**

Sheet metal or other material used in roof and wall construction to protect a building from rainwater penetrating the house structure.

**FLUE**

A vertical duct constructed of sheet metal or clay that channels smoke from a fireplace out of the home.

**FOOTING**

A masonry section, usually concrete, in a rectangular form wider than the bottom of the foundation wall or pier it supports.

**FOUNDATION**

The supporting portion of a structure below the first-floor construction, or below grade, including the footings.

**FRAME CONSTRUCTION**

A type of construction in which the structural parts are wood or depend upon a wood frame for support.

**GABLE**

The portion of the roof above the eave line of a double-sloped roof.

**GABLED LOUVERS**

A vent with angled slats that provides ventilation at the peak of gable ends.

**GRAPHITE LUBRICANT**

A finely powdered graphite used as a lubricant.

**GROUND FAULT CIRCUIT INTERRUPTER (GFCI)**

A specialized electrical device that will interrupt electrical power where a weak electrical loss of ground occurs. Normally installed in areas where water may be present.

**GROUT**

A white or colored plaster-like mortar compound used to fill spaces between ceramic tiles.

**HEADER**

A heavy timber and/or concrete beam that spans open spaces in walls, over doors and windows and provides support to structural members above it.

**HIP ROOF**

A roof that rises by inclined planes from all four sides of a building.

**HONEYCOMB**

In concrete, an open-cell-like surface texture that occurs while pouring concrete.

**HOSE BIB**

An exterior faucet connection for lawn and garden hoses.

**INSULATION**

Any material high in resistance to heat that, when placed in the walls, ceilings, or floors of a structure, will reduce the rate of heat flow.

**JAMB**

The side and headlining of a trimmed doorway, window or other opening.

**JOINT COMPOUND**

A plaster-like compound used with drywall tape to join sheets of drywall into a smooth, continuous panel.

**JOISTS**

The horizontal support members used in constructing a floor or ceiling.

**KEEPER PLATE**

The metal plate that keeps a door lock latch firmly in place.

**LOCKSET**

A door lock.

**LOUVER**

An opening with a series of horizontal slats so arranged as to permit ventilation but to exclude rain, sunlight or vision.

**MASONRY**

Stone, brick, concrete, hollow tile, concrete block, gypsum block or other similar building units or materials or a combination of the same, bonded together with mortar to form a wall, pier, buttress or similar mass.

**MASTIC**

A construction adhesive that is thick and water-proof. Used on roofs and floors.

**MOLDINGS**

Shaped strips of ornamental wood used around doors and windows. Also used for base molding, tile molding, as chair rails and for exterior area molding. Moldings finish the junction of different materials or shapes.

**NAIL POPS**

Nails that come loose from a stud and push joint compound up. Caused by normal wood shrinkage and home settlement.

**POINTING**

The filling and finishing of broken mortar and stone cement masonry joints.

**PONDING**

The collection of water on driveways, walkways, or lawns. Ponding for excessive periods of time is indicative of grading problems.

**RAFTER**

One of a series of structural members of a roof designed to support roof loads. The rafters of a flat roof are sometimes called roof joists.

**LUXURY VINYL FLOORING AND VINYL FLOORING**

Vinyl flooring used in areas such as kitchens, halls, bathrooms and laundry rooms. It is capable of withstanding shock without permanent deformation.

**RIDGE**

The peak or crest of the roof created where opposite side or slopes of the roof meet.

**RIDGE VENT**

An open vent system located along roof peaks, which in conjunction with soffit vents, creates ventilation through the passage of natural air.

**ROOF SHEATHING**

Boards or sheet material fastened to roof rafters on which the shingles or other roof covering is laid.

**SCALING**

In concrete, the breaking away of the top surface of the concrete, caused by a freeze/ thaw cycle. In painting, the flaking or peeling away of paint.

**SHEATHING**

The structural covering, usually wood boards or plywood or oriented strand board (OSB), used over studs or rafters of a structure. Structural building board is normally used only as wall sheathing.

**SHINGLES**

Roof covering of asphalt, asbestos, wood, tile, slate or other material cut to stock lengths, widths and thicknesses.

**SIDING**

The finish covering on the outside walls of a frame building, whether made of horizontal weatherboards, vertical boards with battens, vinyl siding, shingles or other material.

**SILL**

The lowest member of the frame of a structure, resting on the foundation and supporting the floor joists or the uprights of a wall. The member forming the lower side of an opening, as a doorsill or windowsill.

**SILL PLATES**

A support member laid on the top of the foundation wall that serves as a base for the wall framing.

**SILICONE**

A synthetic lubricating compound with high resistance to temperature change and water. When added to caulking, it extends elasticity properties and increases the life of the caulking.

**SOFFIT**

Usually, the underside of an eave or overhanging roof.

**SOFFIT VENT**

A vent located on the ceiling of a roof overhang that allows air to pass through the attic.

**SPACKLE**

See joint compound.

**SPALLING**

Flaking or chipping of stone or other masonry material. Similar to scaling, but the chips and flakes are larger.

**STRUTS**

Vertical supports in the attic used to support sections of the roof.

**STUD**

One of a series of slender wood or metal vertical structural members placed as supporting elements in walls and partitions.

**SUB-FLOORING**

A wood-sheet flooring placed directly over the floor joists that supports the underlayment or floor covering.

**SWALE**

The soil contour on a building lot deliberately shaped to channel rainwater away from the home.

**TACK STRIPS**

A wood strip with exposed tack points that is attached to the sub-flooring or slab and holds stretched wall-to-wall carpeting in position.

**TREAD**

The horizontal surface in a stairway on which the foot is placed.

**TRIM**

The finish materials in a building, such as moldings, applied around openings or at the floor and ceilings of rooms.

**TRUSSES**

Engineered wood structural members used to construct floors and roofs.

**TURNAROUND**

An additional section of driveway where cars can be turned around..

**UNDERLAYMENT**

A flooring layer over the base sub-flooring, over which tile or vinyl floor covering is laid.

**VALLEY**

The internal angle formed by the junction of two sloping sides of a roof.

**VACUUM BREAKER**

Also called a back-flow preventer, this device is placed on exterior faucets to allow water to only flow out of the home.

**VALVE SEAT**

An interior part of the faucet valve assembly where the valve rests

**WALL TIES**

The metal pieces that tie masonry veneer to the frame of the home, or, when pouring concrete, the metal pieces that hold concrete foundation wall forms in place until the concrete cures.

**WASHERS**

Round, rigid rubber or plastic discs used as a sealing device in water faucet valves.

**WEATHER STRIPPING**

A weather-insulating strip of material placed around doors and windows to reduce water entry into the home. Also reduces air infiltration into the home or the escape of conditioned air out of the home.

**WASHOUTS**

An area where water has produced soil erosion.



PO Box 33025 St. Petersburg, FL 33733  
[www.maverick-risk.com](http://www.maverick-risk.com)  
Copyright 2023. All Rights Reserved